



# SERVOSTAR 300

## Digital Servo Amplifier

### Product Manual

Translation of the original manual.

Edition 02/2009

Valid for Hardware Revision 02.01



Keep all manuals as a product component during the life span of the product. Pass all manuals to future users / owners of the product.

File sr300\_e.\*\*\*

**KOLLMORGEN**™

## Record of Document Revisions:

<b>Revision</b>	<b>Remarks</b>
06/2004	First edition
04/2005	Restart lock -AS-, UL-listing, new pinning for X8, several corrections
04/2005a	order numbers 400V types for NA updated
11/2005	Chapter 1 updated, ComCoder wiring corrected, Acuro(BISS)-Interface new, max. station address changed to 127, motor choke changed, SynqNet and EtherCat expansion cards added, chapter 6 restructured, order codes restructured
12/2005	Feedback section, termination resistors X1/X5, CE section
02/2006	Error messages and warnings updated, additional information (SERCOS), AWG cross-sections added, inch dimensions added, analog-in circuit updated, cross section (awg)
05/2006	CAN baud rate coding updated, LED display structure updated, input analog-in updated, BISS interface updated, hardware revision added, Errors/Warnings updated
09/2006	New document structure, new cover design, warning n24, Quickstart integrated
03/2007	New part number scheme, termination resistors CAN interface and X5 corrected, branding updated, chapter leakage current new, chapter "servo system graphics" expanded and moved, chapter "various mains supply networks" moved, trouble shooting reduced, Feedback expanded and restructured, enc emulation, DC-Link expanded, AS restructured, accessories removed
07/2007	Timing diagram motor brake, standards updated (EMC and LVD)
10/2007	Target group, use as directed, standards
05/2008	Safety symbols acc. to ANSI Z535.6, repair, deinstallation, dU/dt info, syntax: "regen" => "brake", techn. data connectors, cable requirements, data brake circuit
06/2008	EC Declaration new, Hiperface corrected, option FAN new
10/2008	SCCR -> 42kA
02/2009	Product brand, single phase operation, repair/disposal request form

## Hardware Revision (HR) History

<b>Hardware Revision</b>	<b>usable Firmware Revision</b>	<b>usable DRIVEGUI.EXE Revision</b>
02.01	≥ 2.18	≥ 1.30 Build 0056

WINDOWS is a registered trademark of Microsoft Corp.

HIPERFACE is a registered trademark of Max Stegmann GmbH

EnDat is a registered trademark of Dr. Johannes Heidenhain GmbH

EtherCat is a registered trademark of Beckhoff Automation GmbH

**Technical changes which improve the performance of the device may be made without prior notice!**

Printed in the Federal Republic of Germany

All rights reserved. No part of this work may be reproduced in any form (by photocopying, microfilm or any other method) or stored, processed, copied or distributed by electronic means without the written permission of Danaher Motion GmbH.

	page
<b>1 General</b>	
1.1 About this manual . . . . .	7
1.2 Target group . . . . .	7
1.3 Hints for the online edition (PDF format) . . . . .	7
1.4 Abbreviations used . . . . .	8
1.5 Symbols used . . . . .	9
1.6 Standards used . . . . .	9
<b>2 Safety</b>	
2.1 Safety Instructions . . . . .	10
2.2 Use as directed . . . . .	11
2.3 Prohibited use . . . . .	11
<b>3 Approvals</b>	
3.1 Conformance with UL and cUL . . . . .	12
3.2 EC conformance . . . . .	12
3.2.1 EC Declaration of Conformity . . . . .	13
3.2.2 European Directives and Standards for the machine builder . . . . .	14
<b>4 Handling</b>	
4.1 Transport . . . . .	15
4.2 Packaging . . . . .	15
4.3 Storage . . . . .	15
4.4 Maintenance, Cleaning . . . . .	15
4.5 Disassembling . . . . .	16
4.6 Repair . . . . .	16
4.7 Disposal . . . . .	16
<b>5 Package</b>	
5.1 Package supplied . . . . .	17
5.2 Nameplate . . . . .	17
5.3 Part number scheme . . . . .	18
<b>6 Technical description</b>	
6.1 The SERVOSTAR 300 family of digital servo amplifiers . . . . .	19
6.2 Technical data . . . . .	21
6.2.1 Technical data for 110/230 V (types S3__6_) . . . . .	21
6.2.2 Technical data for 400/480 V (types S3__0_) . . . . .	22
6.2.3 Inputs / outputs . . . . .	23
6.2.4 Connectors . . . . .	23
6.2.5 Recommended tightening torques . . . . .	23
6.2.6 Fusing . . . . .	23
6.2.7 Ambient conditions, ventilation, mounting position . . . . .	24
6.2.8 Conductor cross-sections . . . . .	24
6.3 Motor holding brake . . . . .	25
6.4 LED display . . . . .	26
6.5 Grounding system . . . . .	26
6.6 Electrical braking (brake circuit) . . . . .	26
6.7 Switch-on and switch-off behavior . . . . .	28
6.7.1 Behavior in standard operation . . . . .	29
6.7.2 Behavior in the event of an error (with standard setting) . . . . .	30
6.8 Stop- / Emergency Stop- Function to EN 60204 . . . . .	31
6.8.1 Stop: Standards . . . . .	31
6.8.2 Emergency Stop: Standards . . . . .	32
6.8.3 Implementation of the Stop Category 0 . . . . .	33
6.8.4 Implementation of the Stop Category 1 . . . . .	34
6.8.5 Implementation of the Stop Category 2 . . . . .	35
6.9 Personnel safe restart lock -AS- . . . . .	36
6.9.1 Safety instructions . . . . .	36
6.9.2 Use as directed . . . . .	37
6.9.3 Technical data and pinning . . . . .	37
6.9.4 Enclosure . . . . .	37
6.9.5 Wiring . . . . .	37

	page
6.9.6 Functional description .....	38
6.9.6.1 Signal diagram (sequence) .....	39
6.9.6.2 Control circuit .....	40
6.9.6.3 Functional test .....	41
6.9.6.4 Mains supply circuit .....	41
6.10 Shock-hazard protection .....	42
6.10.1 Leakage current .....	42
6.10.2 Residual current protective device (RCD) .....	42
6.10.3 Isolating transformers .....	43
<b>7 Mechanical Installation</b>	
7.1 Safety Instructions .....	45
7.2 Guide to mechanical installation .....	45
7.3 Assembly .....	46
7.4 Dimensions .....	47
<b>8 Electrical installation</b>	
8.1 Safety Instructions .....	49
8.2 Guide to electrical installation .....	50
8.3 Wiring .....	51
8.3.1 Safety instructions .....	51
8.3.2 Shielding connection to the front panel .....	52
8.3.3 Technical data for connecting cables .....	53
8.4 Components of a servo system .....	54
8.5 Block diagram .....	55
8.6 Connector assignments .....	56
8.7 Connection diagram (Overview) .....	57
8.8 Electrical supply .....	58
8.8.1 Connection to various mains supply networks .....	58
8.8.2 24V auxiliary supply (X4) .....	59
8.8.3 Mains supply connection (X0), three phase .....	59
8.8.4 Mains supply connection (X0), two phase without neutral .....	59
8.8.5 Mains supply connection (X0), single phase with neutral .....	60
8.9 External brake resistor (X8) .....	61
8.10 DC bus link (X8) .....	61
8.11 Motor connection with brake (X9) .....	62
8.12 Feedback .....	63
8.12.1 Resolver (X2) .....	64
8.12.2 Sine Encoder with BISS (X1) .....	65
8.12.3 Sine Encoder with EnDat 2.1 .....	66
8.12.4 Sine Encoder with HIPERFACE (X1) .....	67
8.12.5 Sine Encoder without data channel (X1) .....	68
8.12.6 Sine Encoder with Hall (X1) .....	69
8.12.7 ROD (AquadB) 5V (X1) .....	70
8.12.8 ROD (AquadB) 5V with Hall (X1) .....	71
8.12.9 ROD (AquadB) 5V (X5) .....	72
8.12.10 ROD (AquadB) 5V with Hall (X5/X1) .....	73
8.12.11 ROD (AquadB) 24V (X3) .....	74
8.12.12 ROD (AquadB) 24V with Hall (X3/X1) .....	75
8.12.13 SSI Encoder (X5) .....	76
8.12.14 Hall sensors (X1) .....	77
8.13 Electronic Gearing, Master-slave operation .....	78
8.13.1 Connection to an incremental encoder (AquadB) master, 5 V (X5) .....	78
8.13.2 Connection to stepper motor controllers (step and direction) .....	79
8.13.2.1 Step/Direction with 5 V signal level (X5) .....	79
8.13.2.2 Step/Direction with 24 V signal level (X3) .....	80
8.14 Encoder emulation .....	81
8.14.1 Incremental encoder output - A quad B (X5) .....	81
8.14.2 SSI encoder output (X5) .....	82
8.15 Digital and analog inputs and outputs .....	83
8.15.1 Analog inputs (X3) .....	83
8.15.2 Digital inputs (X3/X4) .....	84
8.15.3 Digital outputs (X3) .....	85
8.16 RS232 interface, PC connection (X6) .....	86
8.17 CANopen interface (X6) .....	87

	page
<b>9 Setup</b>	
9.1 Safety Instructions . . . . .	89
9.2 Setup software . . . . .	90
9.2.1 General . . . . .	90
9.2.1.1 Use as directed . . . . .	90
9.2.1.2 Software description . . . . .	90
9.2.1.3 Hardware requirements . . . . .	91
9.2.1.4 Operating systems . . . . .	91
9.2.2 Installation under WINDOWS 2000 / XP . . . . .	91
9.3 Quickstart . . . . .	92
9.3.1 Preparation . . . . .	92
9.3.1.1 Unpacking, Mounting and Wiring the Servo Amplifier . . . . .	92
9.3.1.2 Documents . . . . .	92
9.3.1.3 Minimum Wiring for Drive Test . . . . .	93
9.3.2 Connect . . . . .	94
9.3.3 Important Screen Elements . . . . .	95
9.3.4 Setup Wizard . . . . .	96
9.3.4.1 Basic Setup . . . . .	96
9.3.4.2 Units/Mechanical . . . . .	97
9.3.4.3 Motor (rotary) / Feedback . . . . .	98
9.3.4.4 Motor (linear) / Feedback (Encoder) . . . . .	98
9.3.4.5 Save Parameters and Restart . . . . .	99
9.3.5 Motion Service (Jog Mode) . . . . .	99
9.3.6 More Setup Screens . . . . .	100
9.4 Multi-axis systems . . . . .	101
9.4.1 Station address for CAN-bus . . . . .	101
9.4.2 Baud rate for CAN-bus . . . . .	101
9.5 Keypad operation / LED display . . . . .	101
9.5.1 Keypad operation . . . . .	101
9.5.2 Status display . . . . .	102
9.5.3 Standard menu . . . . .	102
9.5.4 Advanced menu . . . . .	103
9.6 Error messages . . . . .	104
9.7 Warning messages . . . . .	105
9.8 Trouble Shooting . . . . .	106
<b>10 Expansions Cards</b>	
10.1 Guide to installation of expansion cards . . . . .	107
10.2 Expansion card -I/O-14/08- . . . . .	108
10.2.1 Front view . . . . .	108
10.2.2 Technical data . . . . .	108
10.2.3 LEDs . . . . .	108
10.2.4 Entering a motion block number (example) . . . . .	108
10.2.5 Connector assignments . . . . .	109
10.2.6 Connection diagram (default) . . . . .	110
10.3 Expansion card -PROFIBUS- . . . . .	111
10.3.1 Front view . . . . .	111
10.3.2 Connection technology . . . . .	111
10.3.3 Connection diagram . . . . .	111
10.4 Expansion card -SERCOS- . . . . .	112
10.4.1 Front view . . . . .	112
10.4.2 LEDs . . . . .	112
10.4.3 Connection technology . . . . .	112
10.4.4 Connection diagram . . . . .	113
10.4.5 Modifying the station address . . . . .	113
10.4.6 Modifying the baud rate and optical power . . . . .	113
10.5 Expansion card -DEVICENET- . . . . .	114
10.5.1 Front view . . . . .	114
10.5.2 Connection technology . . . . .	114
10.5.3 Connection diagram . . . . .	114
10.5.4 Combined module/network status-LED . . . . .	115
10.5.5 Setting the station address (device address) . . . . .	115
10.5.6 Setting the transmission speed . . . . .	115
10.5.7 Bus cable . . . . .	116

	page
10.6 Expansion card -ETHERCAT-	117
10.6.1 Front view	117
10.6.2 LEDs	117
10.6.3 Connection diagram	117
10.7 Expansion card -SYNQNET-	118
10.7.1 Front view	118
10.7.2 NODE ID Switch	118
10.7.3 Node LED table	118
10.7.4 SynqNet Connection, Connector X21B/C (RJ-45)	118
10.7.5 Digital inputs/outputs, connector X21A (SubD 15-pin, socket)	119
10.7.6 Connection diagram digital inputs/outputs, connector X21A	119
10.8 Expansion module -2CAN-	120
10.8.1 Installation	120
10.8.2 Front view	120
10.8.3 Connection technology	120
10.8.4 Connector assignments	121
10.8.5 Connection diagram	121
10.9 Option "FAN", ventilator control	122
<b>11 Appendix</b>	
11.1 Glossary	123
11.2 Order codes	125
11.2.1 Servo amplifiers	125
11.2.2 Expansion cards	125
11.2.3 Mating connectors	125
11.3 Repair-/Disposal request Telefax form	126
11.4 Index	127

# 1 General

## 1.1 About this manual

This manual describes the SERVOSTAR 300 (S300) series of digital servo amplifiers (standard version: 1.5A ...10A rated current).

A more detailed description of the expansion cards that are currently available and the digital connection to automation systems can be found, together with our applications notes, in Acrobat-Reader format on the accompanying CD-ROM (system requirements: WINDOWS, Internet Browser, Acrobat Reader) in different languages.

Technical data and dimensional drawings of accessories such as cables, brake resistors, mains supplies, etc., can be found in the accessories manual.

This documentation can be printed out on any standard commercial printer. A printed copy of the documentation is available from us at extra cost.

More background information can be found in the "Product WIKI", please check [www.servostar.de](http://www.servostar.de).

## 1.2 Target group

This manual addresses personnel with the following qualifications:

Transport : only by personnel with knowledge of handling electrostatically sensitive components.

Unpacking: only by electrically qualified personnel.

Installation : only by electrically qualified personnel.

Setup : only by qualified personnel with extensive knowledge of electrical engineering and drive technology

The qualified personnel must know and observe the following standards:

IEC 60364 and IEC 60664

national accident prevention regulations

**⚠ WARNING** During operation there are deadly hazards, with the possibility of death, severe injury or material damage. The operator must ensure that the safety instructions in this manual are followed. The operator must ensure that all personnel responsible for working with the servo amplifier have read and understood the product manual.

## 1.3 Hints for the online edition (PDF format)

### Bookmarks:

Table of contents and index are active bookmarks.

### Table of contents and index in the text:

The lines are active cross references. Click on the desired line and the appropriate page is accessed.

### Page/chapter numbers in the text:





Page/chapter numbers with cross references are active. Click at the page/chapter number to reach the indicated target.

## 1.4 Abbreviations used

<b>Abbrev.</b>	<b>Meaning</b>
AGND	Analog ground
AS	Restart lock
BTB/RTO	Ready to operate
CAN	Fieldbus (CANopen)
CE	Communauté Européenne
CLK	Clock signal
COM	Serial interface for a PC-AT
DGND	Digital ground (for 24V and digital I/O)
DIN	German Institute for Industrial Standards
Disk	Magnetic storage (diskette, hard disk)
EEPROM	Electrically erasable programmable memory
EMC	Electromagnetic compatibility
EMI	Electromagnetic interference
EN	European Standard
ESD	Electrostatic discharge
F-SMA	Fiber Optic Cable connector according to IEC 60874-2
IEC	International Electrotechnical Commission
IGBT	Insulated-gate bipolar transistor
INC	Incremental interface
ISO	International Organization for Standardization
LED	Light-emitting diode
MB	Megabyte
NI	Zero pulse
PC	Personal computer
PELV	Protected low voltage
PLC	Programmable logic controller
PWM	Pulse-width modulation
RAM	Volatile memory
RBallast / R <sub>BR</sub>	Ballast resistor (= brake resistor or regen resistor)
RBext	External brake resistor
RBint	Internal brake resistor
RES	Resolver
ROD	digital encoder
S1	continuous operation
S3	Intermittent operation
SRAM	Static RAM
SSI	Synchronous serial interface
UL	Underwriters Laboratories
V AC	Alternating voltage
V DC	DC voltage
VDE	Society of German Electrical Technicians



## 1.5 Symboles used

Symbol	Indication
	Indicates a hazardous situation which, if not avoided, will result in death or serious injury.
	Indicates a hazardous situation which, if not avoided, could result in death or serious injury.
	Indicates a hazardous situation which, if not avoided, could result in minor or moderate injury.
	Indicates situations which, if not avoided, could result in property damage.
	This is not a safety symbol. This symbol indicates important notes.

## 1.6 Standards used

Standard used	Equivalent standard	Content
EN 12100	ISO 12100	Safety of machinery: Basic concepts, general principles for design
IEC 60085	EN 60085	Electrical insulation - Thermal evaluation and designation Maintenance
EN 60204	IEC 60204	Safety of Machinery: Electrical equipment of machinery
IEC 60364	EN 60364	Low-voltage electrical installations
EN 60439	IEC 60439	Low-Voltage Switchgear and Controlgear Assemblies
IEC 60664	EN 60664	Insulation coordination for equipment within low-voltage systems
IEC 60721	EN 60721	Classification of environmental conditions
EN 61000	IEC 61000	Electromagnetic compatibility (EMC)
IEC 61131	EN 61131	Programmable controllers
IEC 61491	EN 61491	Electrical equipment of industrial machines – Serial data link for real-time communications between controls and drives.
IEC 61508	EN 61508	Functional safety of electrical/electronic/programmable electronic safety-related systems
EN 61800	IEC 61800	Adjustable speed electrical power drive systems
IEC 62079	EN 62079	Preparation of instructions - Structuring, content and presentation
ISO 898	EN 898-1	Mechanical Properties of Internal and External Screw Fasteners
EN 954	ISO 13849-1	Safety of machinery: Safety-related parts of control systems
ANSI Z535	-	Product safety (symbols, colors, information)
UL 840	-	UL Standard for Safety for Insulation Coordination Including Clearances and Creepage Distances for Electrical Equipment
UL 508C	-	UL Standard for Safety Power Conversion Equipment

EN European Standard  
 IEC International Electrotechnical Commission  
 ISO International Organization for Standardization  
 UL Underwriters Laboratories

## 2 Safety

### 2.1 Safety Instructions

**▲ DANGER** During operation there are deadly hazards, with the possibility of death, severe injury or material damage. Do not open or touch the equipment during operation. Keep all covers and cabinet doors closed during operation. Touching the equipment is allowed during installation and commissioning for properly qualified persons only.

- During operation, servo amplifiers may have uncovered live components, depending on their level of enclosure protection.
- Control and power connections may be live, even though the motor is not rotating.
- Servo amplifiers may have hot surfaces during operation. Surface can reach temperatures above 80°C.

**▲ WARNING** There is a danger of electrical arcing with damage to contacts and personal injury. Never undo any electrical connections to the servo amplifier while it is live. Wait at least five minutes after disconnecting the servo amplifier from the main supply power before touching potentially live sections of the equipment (e.g. contacts) or undoing any connections. Capacitors can still have dangerous voltages present up to five minutes after switching off the supply power. To be sure, measure the voltage in the DC Bus link and wait until it has fallen below 40V.

**▲ CAUTION** Incorrect handling of the servo amplifier can lead to personal injury or material damage. Read this documentation before carrying out the installation and commissioning. It is vital that you keep to the technical data and information on connection requirements (nameplate and documentation). Only properly qualified personnel are permitted to carry out activities such as transport, installation, commissioning and maintenance. Properly qualified persons are those who are familiar with the transport, assembly, installation, commissioning and operation of the product, and who have the appropriate qualifications for their job. The qualified personnel must know and observe the following standards:

- IEC 60364 and IEC 60664
- national accident prevention regulations

**▲ CAUTION** The manufacturer of the machine must produce a hazard analysis for the machine and take appropriate measures to ensure that unforeseen movements do not result in personal injury or material damage.

**NOTICE** Check the Hardware Revision Number of the product (see product label). This revision number must match the Hardware Revision Number on the cover page of the manual.

**NOTICE** The servo amplifiers contain electrostatically sensitive components which may be damaged by incorrect handling. Discharge your body before touching the servo amplifier. Avoid contact with highly insulating materials (artificial fabrics, plastic film etc.). Place the servo amplifier on a conductive surface.

## 2.2 Use as directed

- Servo amplifiers are components that are built into electrical plant or machines, and can only be operated as integral components of such plant or machines.
- The manufacturer of the machine must generate a hazard analysis for the machine, and take appropriate measures to ensure that unforeseen movements cannot cause injury or damage to any person or property.
- Servo amplifiers in the SERVOSTAR 300 series can be supplied from 3-phase grounded (earthed) industrial supply networks (TN-system, TT-system with grounded neutral point, no more than 42kA symmetrical rated current at  $110\text{-}10\%\dots 230\text{V}^{+10\%}$  or  $208\text{-}10\%\dots 480\text{V}^{+10\%}$  depending on the amplifier type).  
Connection to other types of supply networks (with an additional isolating transformer) is described on page 58.
- Periodic overvoltages between phases (L1, L2, L3) and the housing of the servo amplifier must not exceed 1000V crest.  
In accordance with EN 61800, voltage spikes ( $< 50\mu\text{s}$ ) between phases must not exceed 1000V. Voltage spikes ( $< 50\mu\text{s}$ ) between a phase and the housing must not exceed 2000V.
- If the servo amplifiers are used in residential areas, in business/commercial areas, or in small industrial operations, then additional filter measures must be implemented by the user.
- The SERVOSTAR 300 family of servo amplifiers is **exclusively** intended for driving suitable brushless synchronous servomotors and asynchronous motors with closed-loop control of torque, speed and/or position. The rated voltage of the motors must be at least as high as the DC bus link voltage/ $\sqrt{2}$  produced by the servo amplifier ( $U_{n\text{Motor}} \geq U_{\text{DC}}/\sqrt{2}$ ).
- The servo amplifiers must **only** be operated in a closed control cabinet, taking into account the ambient conditions defined on page 24. Ventilation or cooling may be necessary to keep the temperature within the cabinet below 40°C.
- Use only copper conductors for wiring. The conductor cross-sections can be derived from the standard EN 60204 (alternatively for AWG cross-sections: NEC Table 310-16, 60°C or 75°C column).
- Consider the specifications on page 36 when you use the restart lock -AS-.

## 2.3 Prohibited use

- Other use than described in chapter 2.2 is not intended and can lead to damage with persons, equipment or things.
- The use of the servo amplifier in the following environments is prohibited:
  - potentially explosive areas
  - environments with corrosive and/or electrically conductive acids, alkaline solutions, oils, vapours, dusts
  - directly on non-grounded supply networks or on asymmetrically grounded supplies with a voltage  $>240\text{V}$ .
  - on ships or off-shore applications
- Commissioning the servo amplifier is prohibited if the machine in which it was installed,
  - does not meet the requirements of the EC Machinery Directive
  - does not comply with the EMC Directive or with the Low Voltage Directive
  - does not comply with any national directives

## 3 Approvals

### 3.1 Conformance with UL and cUL

This servo amplifier is listed under UL file number **E217428**.

UL (cUL)-certified servo amplifiers (Underwriters Laboratories Inc.) fulfil the relevant U.S. and Canadian standard (in this case UL 840 and UL 508C).

This standard describes the fulfillment by design of minimum requirements for electrically operated power conversion equipment, such as frequency converters and servo amplifiers, which is intended to eliminate the risk of fire, electric shock, or injury to persons, being caused by such equipment. The technical conformance with the U.S. and Canadian standard is determined by an independent UL (cUL) inspector through the type testing and regular checkups.

Apart from the notes on installation and safety in the documentation, the customer does not have to observe any other points in direct connection with the UL (cUL)-certification of the equipment.

#### **UL 508C**

UL 508C describes the fulfillment by design of minimum requirements for electrically operated power conversion equipment, such as frequency converters and servo amplifiers, which is intended to eliminate the risk of fire being caused by such equipment.

#### **UL 840**

UL 840 describes the fulfillment by design of air and insulation creepage spacings for electrical equipment and printed circuit boards.

### 3.2 EC conformance

Conformance with the EC EMC Directive 2004/108/EC and the Low Voltage Directive 2006/95/EC is mandatory for the supply of servo amplifiers within the European Community. Product standard EN 61800-3 is applied to ensure conformance with the EMC Directive.

The servo amplifier meets the noise immunity requirements to the 2nd environmental category (industrial environment). For noise emission the amplifier meets the requirement to a product of the category C2 (motor cable  $\leq 10\text{m}$ ).

#### **NOTICE**

**This product can cause high-frequency interferences in non industrial environments which can require measures for interference suppression.**

With a motor cable length of 10m or longer, the servo amplifier meets the requirement to the category C3.

The servo amplifiers have been tested by an authorized testing laboratory in a defined configuration, using the system components that are described in this documentation. Any divergence from the configuration and installation described in this documentation means that you will be responsible for carrying out new measurements to ensure conformance with regulatory requirements. The standard EN 61800-5-1 is applied to ensure conformance with the Low Voltage Directive.

## 3.2.1

## EC Declaration of Conformity

**EC Declaration of Conformity**

Document No.: GL-11/22/24/08

We, the company

Danaher Motion GmbH  
Wacholderstraße 40-42  
D-40489 Düsseldorf

hereby in sole responsibility declare the conformity of the product series

**Servo amplifier SERVOSTAR™ 300**

with the following standards:

- EC Directive 2004/108/EC  
Electromagnetic compatibility  
Used standard EN61800-3 (07/2005)
- EC Directive 2006/95/EC  
Electrical devices for use in special voltage limits  
Used standard EN61800-5-1 (04/2008)

Year of EC-Declaration      2004

Issued by:                      Product Management  
   Siegfried Fischer  
   Düsseldorf,                      12.06.2008

Legally valid signature

This Declaration does not contain any assurance of properties in the meaning of product liability.

The notes on safety and protection in the operating instructions must always be observed.

The above-mentioned company has the following technical documentation for examination:

- Proper operating instructions
- Setup Software
- Diagrams / software source codes (for EU authority only)
- Test certificates (for EU authority only)
- Other technical documentation (for EU authority only)

### 3.2.2 European Directives and Standards for the machine builder

Servo amplifiers are components that are intended to be incorporated into electrical plant and machines for industrial use. When the servo amplifiers are built into machines or plant, the amplifier must not be used until it has been established that the machine or equipment fulfills the requirements of the

- EC Machinery Directive (98/37/EC)
- EC EMC Directive (2004/108/EC)
- EC Low Voltage Directive (2006/95/EC)

Standards to be applied for conformance with the EC Machinery Directive (98/37/EC)

EN 60204-1 (Safety and Electrical Equipment in Machines)

EN 12100 (Safety of Machines)



**The manufacturer of the machine must generate a hazard analysis for the machine, and must implement appropriate measures to ensure that unforeseen movements cannot cause injury or damage to any person or property.**

Standards to be applied for conformance with the Low Voltage Directive (2006/95/EC):

EN 60204-1 (Safety and Electrical Equipment in Machines)

EN 60439-1 (Low-voltage switchgear and controlgear assemblies)

Standards to be applied for conformance with the EMC Directive (2004/108/EC):

EN 61000-6-1 / 2 (Interference Immunity in Residential & Industrial Areas)

EN 61000-6-3 / 4 (Interference Generation in Residential & Industrial Areas)

The manufacturer of the machine/plant is responsible for ensuring that it meets the limits required by the EMC regulations. Advice on the correct installation for EMC (such as shielding, grounding, treatment of connectors and cable layout) can be found in this documentation.



**The machine/plant manufacturer must check whether other standards or EC Directives must be applied to the machine/plant.**

We only guarantee the conformance of the servo system with the standards cited in this chapter if the components (motor, cables, chokes etc.) are those supplied by us.

## 4 Handling

### 4.1 Transport

- Transport by qualified personnel in the manufacturer's original recyclable packaging
- Avoid shocks while transporting
- Transport temperature: -25 to +70°C, max. rate of change 20K / hour
- Transport humidity: max. 95% relative humidity, no condensation

#### NOTICE

- **The servo amplifiers contain electrostatically sensitive components, that can be damaged by incorrect handling. Discharge yourself before touching the servo amplifier. Avoid contact with highly insulating materials, such as artificial fabrics and plastic films. Place the servo amplifier on a conductive surface.**
- If the packaging is damaged, check the unit for visible damage. In such an event, inform the shipper and the manufacturer.

### 4.2 Packaging

- Recyclable cardboard with inserts
- Dimensions: (HxWxD) 115x365x275mm
- Labeling: instrument label on outside of box

### 4.3 Storage

- Storage only in the manufacturer's original recyclable packaging
- Max. stacking height 8 cartons
- Storage temperature -25 to +55°C, max. rate of change 20K / hour
- Storage humidity 5 ... 95% relative humidity, no condensation
- Storage duration:  
Less than 1 year: without restriction.  
More than 1 year: capacitors must be **re-formed** before setting up and operating the servo amplifier. To do this, remove all electrical connections and apply single-phase 230V AC for about 30 minutes to the terminals L1 / L2.

### 4.4 Maintenance, Cleaning

The instruments do not require any maintenance, opening the instruments invalidates the warranty.

**Cleaning :** — if the casing is dirty: clean with Isopropanol or similar

**NOTICE: do not immerse or spray**

- Dirt inside the unit: must be cleaned by the manufacturer
- For dirty protective grill on fan: clean with a dry brush



## 4.5 Disassembling

Observe the sequence below, if a servo amplifier has to be disassembled (e.g. for replacement).

### 1. Electrical disconnection

**⚠ WARNING** Switch off the main switch of the switchgear cabinet and the fuses that supply the system.

Wait at least five minutes after disconnecting the servo amplifier from the main supply power before touching potentially live sections of the equipment (e.g. contacts) or undoing any connections. To be sure, measure the voltage in the DC Bus link and wait until it has fallen below 40V.

Remove the connectors. Disconnect the earth (ground) connection at last.

### 2. Check temperature

**⚠ CAUTION** During operation the heat sink of the servo amplifier may reach temperatures above 80°C (176°F). Before touching the device, check the temperature and wait until it has cooled down below 40°C (104°F).

### 3. Disassembling

Disassemble the servo amplifier (reverse of the procedure described in chapter "Mechanical installation").

## 4.6 Repair

Repair of the servo amplifier must be done by the manufacturer. Opening the devices means loss of the guarantee. Use the telefax form on page 126 for repair request. You'll receive the current dispatch information.

Disassemble the equipment as described in chapter 4.5 and send it in the original packaging to the address given in the dispatch information.

## 4.7 Disposal

In accordance to the WEEE-2002/96/EC-Guidelines we take old devices and accessories back for professional disposal. Transport costs are the responsibility of the sender. Use the telefax form on page 126 for disposal request. You'll receive the current dispatch information.

Disassemble the equipment as described in chapter 4.5 and send it in the original packaging to the address given in the dispatch information.



## 5 Package

### 5.1 Package supplied

When an amplifier from the SERVOSTAR 300 series is ordered (order numbers ⇒p.125), the following is supplied:

- SERVOSTAR 3xx
- Mating connectors X0, X3, X4, X8
- Mating connector X9 only with SERVOSTAR 303-310 (S3xx6)
- Product manual and online documentation on CD-ROM
- Setup software DRIVEGUI.EXE on CD-ROM



**The mating SubD connectors are not part of the package!**

**Accessories :** (must be ordered separately, if required; description see accessories manual)

- motor cable (prefabricated) with special shield clamp, or both power connectors separately, with the motor cable as a cut-off length
- feedback cable (prefabricated)  
or both feedback connectors separately, with the feedback cable as a cut-off length
- motor choke 3YL, for motor cables longer than 25 meters
- external brake resistor BAR(U)
- communication cable to the PC (⇒ p.86) for setting parameters from a PC
- power cable, control cables, fieldbus cables (as cut-off lengths)

### 5.2 Nameplate

The nameplate depicted below is attached to the side of the servo amplifier. The information described below is printed in the individual fields.

Servo amplifier type	Serial number	Comments	Enclosure Rating
<div style="display: flex; justify-content: space-between;"> <div style="width: 45%;"> <p>Danaher Motion GmbH Wacholderstr. 40-42 D-40489 Düsseldorf www.DanaherMotion.com</p> </div> <div style="width: 45%;"> <p>Customer Support Europe Tel. +49 (0)203 / 99790 Italy Tel. +39 (0)362 / 594260 North America Tel. +1 540 633 3400</p> </div> </div>			
<p>Typenbezeichnung      Model Number      Ser. Nr      Ser. No.      Bemerkung      Comment</p>			
<p>Spannungsversorgung      Power Supply      Nennstrom      Nom. Current      Schutzart      Encl. Rating</p>			
<p>Umgebungstemp.      Ambient temp.      Hardware Revision</p>			
<p>example      Made in Austria      example</p>			
max. ambient temperature	Electrical supply Installed load	Output current in S1 operation	Hardware Revision

5.3 Part number scheme

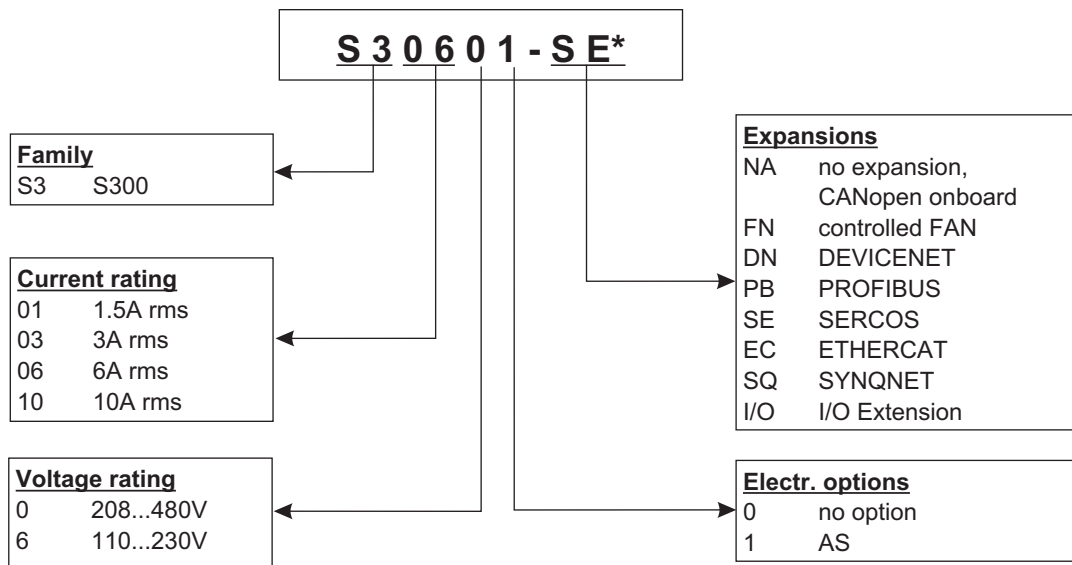

\* additional coding defines customer specific specials

Comparison device name -> part number

Device Name	Part Number
SERVOSTAR 303	S30361-NA
SERVOSTAR 306	S30661-NA
SERVOSTAR 310	S31061-NA
SERVOSTAR 341	S30101-NA
SERVOSTAR 343	S30301-NA
SERVOSTAR 346	S30601-NA

## 6 Technical description

### 6.1 The SERVOSTAR 300 family of digital servo amplifiers

#### Standard version

- Two voltage classes with large nominal voltage range
  - 1 x 110V<sub>-10%</sub> ... 3 x 230V<sup>+10%</sup> (SERVOSTAR 303-310, S3xx6)
  - 3 x 208V<sub>-10%</sub> ... 3 x 480V<sup>+10%</sup> (SERVOSTAR 341-346, S3xx0)
- Shielding connection directly on the servo amplifier
- Two analog inputs onboard
- CANopen onboard (default: 500 kBaud), for integration in CAN-bus systems and for setting parameters for several drives via the PC interface of one of the amplifiers
- Slot for an expansion card
- RS232 and pulse direction interface onboard
- Restart lock -AS- for personnel safety onboard, ⇒ p. 36
- Intelligent position controller onboard
- Multi feedback support
- Synchronous servomotors, linear motors, asynchronous motors, high frequency spindles and DC motors can be used

#### Power section

- Directly on grounded 3-phase supply, 110V<sub>-10%</sub> or 230V<sub>-10%</sub> up to 480V<sup>+10%</sup> TN-network or TT-network with grounded neutral point, 42kA max. symmetrical current rating, connection to other supply types only via isolating transformer, ⇒p.58
- B6 bridge rectifier, integral supply filter and soft-start circuit
- Single-phase supply operation possible (e.g. for setup)
- Fusing (e.g. fusible cutout) to be provided by the user
- Shielding All shielding connections are made directly on the amplifier
- Output stage IGBT module with floating current measurement
- Brake circuit with dynamic distribution of the regenerated power between several amplifiers on the same DC bus link circuit. Internal brake resistor as standard, external brake resistors if required.
- DC bus link voltage 135 ... 450 V DC or 260 ... 900 V DC, can be connected in parallel.
- Interference suppression filters are integrated for the electrical supply feed and the 24V auxiliary supply voltage (with motor cable ≤ 10m for C2 as per EN 61800-3, with motor cable > 10m for C3 as per EN 61800-3).

#### Integrated safety

- Appropriate insulation/creepage distances and electrical isolation ensure safe electrical separation, as per EN 61800-5-1, between the power input / motor connections and the signal electronics.
- Soft-start, overvoltage detection, short-circuit protection, phase-failure monitoring.
- Temperature monitoring of the servo amplifier and motor (if our motors and prefabricated cables are used).

**Auxiliary supply voltage 24V DC**

- Electrically isolated, internal fusing, from an external 24V DC power supply unit with, for instance, isolating transformer or uninterruptible power supply.

**Operation and parameter setting**

- With our user-friendly setup software, for setup via the serial interface of a PC.
- If no PC is available: direct operation by two keys on the servo amplifier and a 3-character LED display.
- Fully programmable via RS232 interface.

**Completely digital control**

- Digital current controller (space vector, pulse-width modulation, 62.5  $\mu$ s)
- Adjustable digital speed controller (62.5  $\mu$ s)
- Integrated position controller, with adaptation possibilities for all applications (250  $\mu$ s)
- Integrated step/direction interface for connecting a servomotor to a stepper controller
- Evaluation of resolver signals and sine-cosine signals of high-resolution encoders
- Encoder emulation (incremental, compatible with A quad B or SSI)

**Comfort functions**

- 2 programmable analog inputs
- 4 programmable digital inputs
- 2 programmable digital outputs
- programmable logical combinations of digital signals

**Expansions**

- Option FAN, ventilator control, cannot be inserted later,  $\Rightarrow$  p.122
- I/O-14/08 expansion card,  $\Rightarrow$  p.108
- PROFIBUS DP expansion card,  $\Rightarrow$  p.111
- SERCOS expansion card,  $\Rightarrow$  p.112
- DeviceNet expansion card,  $\Rightarrow$  p.114
- EtherCat expansion card,  $\Rightarrow$  p. 117
- SynqNet expansion card,  $\Rightarrow$  p. 118
- -2CAN- expansion module, separated connectors for CAN-bus and RS232,  $\Rightarrow$  p.120
- Several third-party expansion cards (ModBus, LightBus, FIP-IO etc. please contact the manufacturer for further information)

## 6.2 Technical data

### 6.2.1 Technical data for 110/230 V (types S3\_ \_6\_)

		SERVOSTAR		
Electrical data	DIM	303	306	310
Order Code	—	S30361	S30661	S31061
Rated supply voltage (grounded supply, phase to phase)	V~	1 x 110V <sup>-10%</sup> ... 1 x 230V <sup>+10%</sup> 3 x 110V <sup>-10%</sup> ... 3 x 230V <sup>+10%</sup> 50/60 Hz		
Rated input power for S1 operation	kVA	1.1	2.4	4
Max. DC bus link voltage	V=	450		
Rated output current (rms value, ± 3%)				
at 1x115V (observe p. 60)	Arms	3,5*	8*	10*
at 1x230V (observe p. 60)	Arms	3*	6*	10*
at 3x115V	Arms	3.5	8	10
at 3x230V	Arms	3	6	10
Peak output current (current for approx. 5s, ± 3%)				
at 1x115V (observe p. 60)	Arms	9*	15*	20*
at 1x230V (observe p. 60)	Arms	9*	15*	20*
at 3x115V	Arms	9	15	20
at 3x230V	Arms	9	15	20
Switching frequency of the output stage	kHz	8		
at reduced current (50%)	kHz	16		
Voltage rise speed dU/dt (see hints on page 62!)				
at 1x115V	kV/μs	3,0		
at 1x230V	kV/μs	3,3		
at 3x115V	kV/μs	3,0		
at 3x230V	kV/μs	3,3		
Technical data for brake circuit	—	⇒ p.26		
Threshold for overvoltage switch-off				
at 115V	VDC	235		
at 230V	VDC	455		
Motor inductance min.				
at 1x115V	mH	3.7	3.7	3.7
at 1x230V	mH	4.3	4.3	4.3
at 3x115V	mH	2.1	1.3	1.0
at 3x230V	mH	4.3	2.6	1.9
Motor inductance max.	mH	Consult our customer support		
Form factor of the output current (rated conditions, min. load inductance)	—	1.01		
Bandwidth of current controller	kHz	> 1.2		
Residual voltage drop at rated current	V	4		
Thermal dissipation, output stage disabled	W	12		
Thermal dissipation at rated current (incl. PSU losses, without brake dissipation)	W	35	60	90
<b>Mechanical data</b>				
Weight	kg	approx. 2.6		
Height, without connectors	mm	275	279	
Width	mm	70		
Depth, without connectors	mm	171		
Depth, with connectors	mm	< 200		

\* in single-phase applications nom./peak current is limited to value below nominal value dependent on the motor constant K<sub>t</sub> and the motor speed (see p.60).

6.2.2 Technical data for 400/480 V (types S3\_ \_0\_)

Electrical data		DIM	SERVOSTAR		
			341	343	346
Order Code	—	S30101	S30301	S30601	
Rated supply voltage (grounded supply, phase to phase)	V~	3 x 208V <sup>-10%</sup> ... 480V <sup>+10%</sup> , 50/60 Hz			
Rated input power for S1 operation	kVA	1.2	2.5	5	
Max. DC bus link voltage	V=	900			
Rated output current (rms value, ± 3%)					
at 3x208V	Arms	2	5	6	
at 3x230V	Arms	2	5	6	
at 3x400V	Arms	1.5	4	6	
at 3x480V	Arms	1.5	3	6	
Peak output current (max. approx. 5s, ± 3%)					
at 3x208V	Arms	4.5	7.5	12	
at 3x230V	Arms	4.5	7.5	12	
at 3x400V	Arms	4.5	7.5	12	
at 3x480V	Arms	4.5	7.5	12	
Switching frequency of the output stage	kHz	8			
at reduced current (50%)	kHz	16			
Voltage rise speed dU/dt (see hints on page 62!)					
at 3x208V	kV/μs	3,0			
at 3x230V	kV/μs	3,3			
at 3x400V	kV/μs	5,7			
at 3x480V	kV/μs	6,9			
Technical data for brake circuit	—	⇒ p.26			
Threshold for overvoltage switch-off					
a 230V	VDC	455			
a 400V	VDC	800			
a 480V	VDC	900			
Motor inductance min.					
at 3x208V	mH	7.7	4.6	2.9	
at 3x230V	mH	8.5	5.1	3.2	
at 3x400V	mH	14.8	8.9	5.6	
at 3x480V	mH	17.8	10.7	6.7	
Motor inductance max.	mH	Consult our customer support			
Form factor of the output current (rated conditions, min. load inductance)	—	1.01			
Bandwidth of subordinate current controller	kHz	> 1.2			
Residual voltage drop at rated current	V	5			
Thermal dissipation, output stage disabled	W	12			
Thermal dissipation at rated current (incl. PSU losses, without brake dissipation)	W	40	60	90	
<b>Mechanical data</b>					
Weight	kg	approx. 2.7			
Height, without connectors	mm	275	278		
Width	mm	70			
Depth, without connectors	mm	171			
Depth, with connectors	mm	< 235			

### 6.2.3 Inputs / outputs

Interface	electr. data
Analog inputs 1, 2 (resolution 14/12 bit)	±10V
Max. common-mode voltage	±10V
Digital control inputs	as per EN 61131-2 Type 1, max. 30VDC
Digital control outputs, active high	open Emitter, max. 30VDC, 10mA
BTB/RTO output, relay contacts	max. 30VDC, max 42VAC 500mA
Auxiliary supply voltage, electrically isolated, without motor brake/fan	20V - 30V 1A
Auxiliary supply voltage, electrically isolated, with motor brake/fan	24V (-0% +15%) 2.5A ( <b>check voltage drop !</b> )
Min./max. output current to brake	0.15A / 1.5A

### 6.2.4 Connectors

Connector	Type	max. cross section* <sup>1</sup>	permitted current* <sup>2</sup>	permitted tension* <sup>3</sup>
Control signals X3, X4	Combicon connector	1,5mm <sup>2</sup>	4A	160V
S303-310 Power signals X0,X8,X9	Combicon connector	2,5mm <sup>2</sup>	12A	630V
S341-346 Power signals X0,X8,X9	Combicon connector	4mm <sup>2</sup>	16A	1000V
Resolver input X2	SubD 9-pin (socket)	0,5mm <sup>2</sup>	1A	<100V
Encoder input X1	SubD 15-pin (socket)	0,5mm <sup>2</sup>	1A	<100V
PC interface, CAN X6	SubD 9-pin (plug)	0,5mm <sup>2</sup>	1A	<100V
Encoder emulation, ROD/SSI X5	SubD 9-pin (plug)	0,5mm <sup>2</sup>	1A	<100V

\*1 single-line connection

\*2 single-line connection with recommended conductor cross section (chapt. 6.2.8)

\*3 rated voltage with pollution level 2

### 6.2.5 Recommended tightening torques

Connector	Tightening torque
X0, X8, X9	0.5..0.6 Nm
Grounding bolt	3.5 Nm

### 6.2.6 Fusing

#### Internal fusing

Circuit	Internal fuse
Auxiliary voltage 24V	3.15 A (slow)
Brake resistor	electronic

#### External fusing

Wire fuses or similar	SERVOSTAR 303*, 341*, 343*	SERVOSTAR 306*, 310*, 346*
AC supply feed $F_{N1/2/3}$ (X0/1; 2; 3)	6 AT (FRx-6)	10 AT (FRx-10)
24V feed $F_{H1/2}$	max. 8 AF (FRx-12)	
Brake resistor $F_{B1/2}$ (X8/2; 4)	6 AT (FRS-6)	6 AT (FRS-6)

US fuses in brackets, x = S or S-R for 480V applications

x = N or N-R for 230V applications

\* order code reference see p. 18

6.2.7 Ambient conditions, ventilation, mounting position

<b>Storage hints</b>	⇒ p.15
<b>Transport hints</b>	⇒ p.15
<b>Supply voltage</b>	303-310*: 1x110V-10% ...1x230V <sup>+10%</sup> , 50/60 Hz 3x110V-10% ...3x230V <sup>+10%</sup> , 50/60 Hz 341-346*: 3x208V-10% ...3x 480V <sup>+10%</sup> , 50/60 Hz
<b>Auxiliary voltage</b> without brake and fan with brake or fan	20 V DC ... 30 V DC 24 V DC (-0% +15%), check voltage drop !
<b>Ambient temperature in operation</b>	0...+40°C under rated conditions +40...+55°C with power derating 2.5% / °C
<b>Humidity in operation</b>	rel. humidity 85%, no condensation
<b>Site altitude</b>	up to 1000 meters a.m.s.l. without restriction 1000...2500 meters a.m.s.l. with power derating 1.5% / 100meters
<b>Pollution level</b>	Pollution level 2 as per IEC 60664-1
<b>Vibrations</b>	Class 3M2 according to IEC 60721-3-3
<b>Noise emission</b>	max. 45 dB(A)
<b>Enclosure protection</b>	IP 20
<b>Mounting position</b>	vertical ⇒ p.46
<b>Ventilation 1 A and 3 A types</b> all other types	<b>natural convection</b> <b>built-on fan (optionally controlled, ⇒ p.122)</b>
<b>NOTICE</b>	<b>Make sure that there is sufficient forced ventilation within the control cabinet.</b>

\* order code reference see p. 18

6.2.8 Conductor cross-sections

Following EN 60204, we recommend for **single-axis systems**:

<b>AC connection</b>	1.5 mm <sup>2</sup> (14awg)	600V,80°C
<b>DC bus link</b> <b>Brake resistor</b>	1.5 mm <sup>2</sup> (14awg)	1000V, 80°C, shielded for lengths >20cm
<b>Motor cables up to 25 m</b>	1 - 1.5 mm <sup>2</sup> (14awg)	600V, 80°C, shielded, capacitance <150pF/m
<b>Motor cables 25m to 50 m, with motor choke 3YL</b>	1 mm <sup>2</sup> (14awg)	600V,80°C, shielded, capacitance <150pF/m
<b>Resolver, motor thermal control</b>	4x2x0.25 mm <sup>2</sup> (22awg), max. 100m	twisted pairs, shielded, capacitance <120pF/m
<b>Encoder, motor thermal control</b>	7x2x0.25 mm <sup>2</sup> (22awg), max.50m	twisted pairs, shielded
<b>ComCoder, motor thermal control</b>	8x2x0.25 mm <sup>2</sup> (22awg), max.25m	twisted pairs, shielded
<b>Setpoints, AGND</b>	0.25 mm <sup>2</sup> (22awg), max 30m	twisted pairs, shielded
<b>Control signals, BTB, DGND</b>	0.5 mm <sup>2</sup> (20awg), max 30m	
<b>Holding brake (motor)</b>	min. 0.75 mm <sup>2</sup> (18awg)	600V, 80°C, shielded, check voltage drop
<b>+24 V / DGND</b>	max. 2.5 mm <sup>2</sup> (12awg)	check voltage drop

**NOTICE** For multi-axis systems, observe the specific operating conditions for your system. To reach the max. permitted cable length, observe cable requirements ⇒ p. 53.

\* Kollmorgen North America supplies cables up to 39 meters  
Kollmorgen Europe supplies cables up to max. length



### 6.3 Motor holding brake

A 24V / max.1.5A holding brake in the motor can be controlled directly by the amplifier.

**CAUTION** Check voltage drop, measure the voltage at brake input and check brake function (brake and no brake). This function does not ensure personnel safety!

The brake function must be enabled through the BRAKE setting (screen page: Motor). In the diagram below you can see the timing and functional relationships between the ENABLE signal, speed setpoint, speed and braking force. All values can be adjusted with parameters, the values in the diagram are default vales.

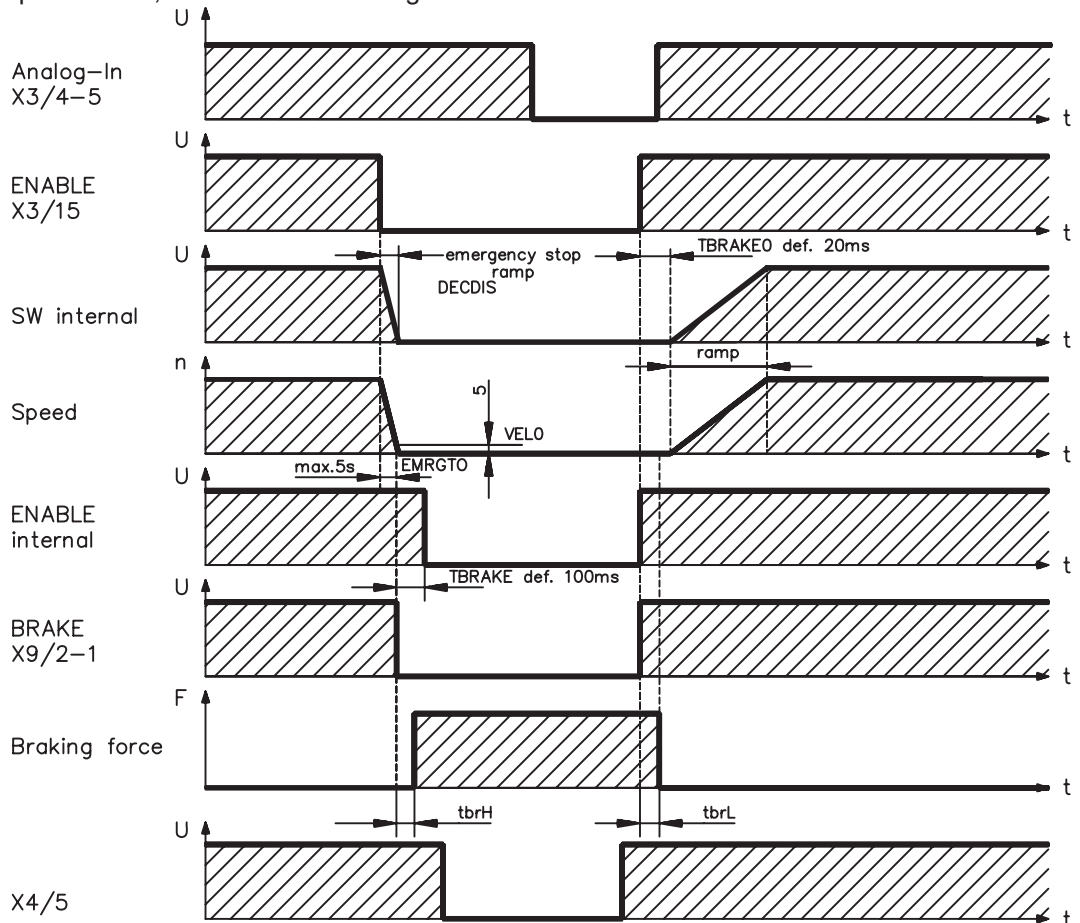

During the internal ENABLE delay time of 100ms (DECDIS), the speed setpoint of the servo amplifier is internally driven down an adjustable ramp to 0V. The output for the brake is switched on when the speed has reached 5 rpm (VELO), at the latest after 5 seconds (EMRGTO).

The rise ( $f_{brH}$ ) and fall ( $f_{brL}$ ) times of the holding brake that is built into the motor are different for the various types of motor (see motor manual). A description of the interface can be found on page 62. Operation of the brake in a manner that provides personnel safety requires an additional "make" contact in the brake circuit, and a suppressor device, such as a varistor, for the brake circuit.

#### Recommended circuit:

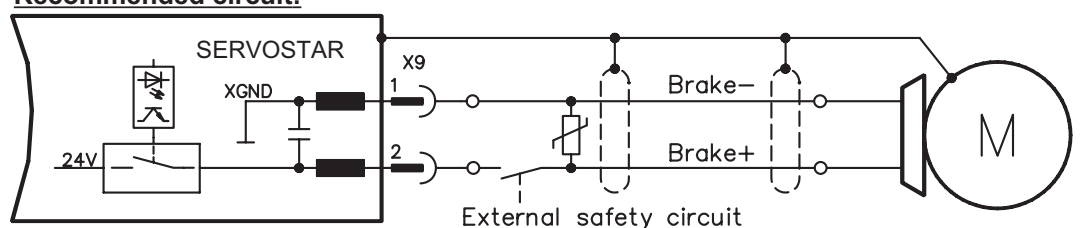

## 6.4 LED display

A 3-character LED display indicates the status of the amplifier after switching on the 24V supply (⇒ p.103). When the keys on the front panel are used, the parameter and function numbers are shown, as well as the numbers for any errors that may occur (⇒ p.104).

## 6.5 Grounding system

AGND — analog inputs, internal analog ground, encoder emulation, RS232, CAN  
DGND — digital inputs/outputs and the 24V supply, optically isolated.

## 6.6 Electrical braking (brake circuit)

During electrical braking with the aid of the motor, energy is fed back into the servo amplifier. This regenerative energy is dissipated as heat in the brake resistor. The brake resistor is switched in by the brake circuit.

The setup software can be used to adapt the brake circuit (thresholds) according to the electrical supply voltage.

Our customer service can help you with the calculation of the brake power that is necessary for your system. A simple method is described in the Online help of the setup software.

A description of the interface can be found on page 61.

### Functional description:

1.- Individual amplifiers, **not coupled** through the DC bus link circuit (DC+, DC-)

When the energy fed back from the motor has an average or peak power that exceeds the preset level for the brake power rating, then the servo amplifier generates the warning “n02 brake power exceeded” and the brake circuit is switched off.

The next internal check of the DC bus link voltage (after a few milliseconds) detects an overvoltage and the output stage is switched off, with the error message “Overvoltage F02” (⇒ p.104).

The BTB/RTO contact (terminals X3/2,3) will be opened at the same time (⇒p.85)

2.- Several servo amplifiers **coupled** through the DC bus link (DC+, DC-)

Using the built-in brake circuit, several amplifiers (even with different current ratings) can be operated off a common DC bus link, without requiring any additional measures.

The **combined (peak and continuous) power** of all amplifiers is always available. The switch-off on overvoltage takes place as described under 1. (above) for the amplifier that has the lowest switch-off threshold (resulting from tolerances).

Technical data of the brake circuits dependent on the amplifiers type and the mains voltage situation see table on the next page.

## Technical Data:

Brake circuit			Supply voltage / V			
Type	Rated data	DIM	115	230	400	480
303 (S30361)	Switch-on (upper) threshold of brake circuit	V	200	400	—	
	Overvoltage F02	V	235	455	—	
	Internal brake resistor (RBint)	Ohm	66	66	—	
	Continuous power internal brake resistor (RBint)	W	20	20	—	
	Max. brake power (average for 1s)	kW	0,4	0,35	—	
	Pulse brake power	kW	0,84	3	—	
	External brake resistor (RBext), optional	Ohm	66	66	—	
	Contuous brake power external (RBext)	kW	0,3	0,3	—	
306 / 310 (S30661/S31061)	Switch-on (upper) threshold of brake circuit	V	200	400	—	
	Overvoltage F02	V	235	455	—	
	Internal brake resistor (RBint)	Ohm	66	66	—	
	Continuous power internal brake resistor (RBint)	W	50	50	—	
	Max. brake power (average for 1s)	kW	0,84	0,88	—	
	Pulse brake power	kW	0,84	3	—	
	External brake resistor (RBext), optional	Ohm	66	66	—	
	Contuous brake power external (RBext)	kW	1	1	—	
341 (S30101)	Switch-on (upper) threshold of brake circuit	V	—	400	720	840
	Overvoltage F02	V		455	800	900
	Internal brake resistor (RBint)	Ohm		91	91	91
	Continuous power internal brake resistor (RBint)	W		20	20	20
	Max. brake power (average for 1s)			0,35	0,33	0,34
	Pulse brake power	kW		2,1	7	9
	External brake resistor (RBext), optional	Ohm		91	91	91
	Contuous brake power external (RBext)	kW		0,3	0,3	0,3
343 / 346 (S30301/S30601)	Switch-on (upper) threshold of brake circuit	V	—	400	720	840
	Overvoltage F02	V		455	800	900
	Internal brake resistor (RBint)	Ohm		91	91	91
	Continuous power internal brake resistor (RBint)	W		50	50	50
	Max. brake power (average for 1s)			0,91	0,86	0,85
	Pulse brake power	kW		2,1	7	9
	External brake resistor (RBext), optional	Ohm		91	91	91
	Contuous brake power external (RBext)	kW		1,0	1,0	1,0



Suitable external brake resistors can be found in our accessories manual.

## 6.7 Switch-on and switch-off behavior

This chapter describes the switch-on and switch-off behavior of the SERVOSTAR and the steps required to achieve operational stopping or emergency stop behavior that complies with standards.



**The servo amplifier's 24 V supply must remain constant. The ASCII commands ACTFAULT (error response) and STOPMODE (ENABLE signal response) dictate how the drive will behave.**

ACTFAULT / STOPMODE	Behavior (see also ASCII reference in the online help of the setup software)
0	Motor coasts to a standstill in an uncontrolled manner
1 (default)	Motor is braked in a controlled manner

### Behavior during a power failure

The servo amplifiers use an integrated circuit to detect if one or more input phases (power supply feed) fail. The behavior of the servo amplifier is set using the setup software: Under “**Response to Loss of Input Phase**” (PMODE) on the **Basic Setup** screen, select:

- **Warning** if the higher-level control system is to bring the drive to a standstill: Warning n05 is output if an input phase is missing, and the motor current is limited to 4 A. The servo amplifier is not disabled. The higher-level control system can now selectively end the current cycle or start bringing the drive to a standstill. Therefore, the error message “MAINS BTB, F16” is output on a digital output of the servo amplifier and evaluated by the control system, for instance.
- **Error message** if the servo amplifier is to bring the drive to a standstill: Error message F19 is output if an input phase is missing. The servo amplifier is disabled and the BTB contact opens. Where the factory setting is unchanged (ACTFAULT=1), the motor is braked using the set “EMERGENCY STOP RAMP”.

### Behavior when undervoltage threshold is reached

If the undervoltage threshold is undershot in the DC bus link (the threshold value depends on the type of servo amplifier), the error message “UNDERVOLTAGE, F05” is displayed. The drive response depends on the ACTFAULT/STOPMODE setting.

### Behavior with enabled “holding brake” function

Servo amplifiers with an enabled holding brake function have a special procedure for switching off the output stage (⇒ p. 25). Removing the ENABLE signal triggers electrical braking. As with all electronic circuits, the general rule applies that there is a possibility of the internal “holding brake” module failing. Bringing a motor to a standstill using a holding brake in a way that is personnel safe also requires an electromechanical “make” contact for the holding equipment and a suppressor device for the brake.

### Behavior of the restart lock -AS-

With the personnel safe, TÜV-approved restart lock –AS-, the drive can be secured on standstill using its internal electronics so that even when power is being supplied, the drive shaft is protected against unintentional restart. The chapter “Personnel safe restart lock -AS-” describes how to use the restart lock –AS-. See page 36 onwards.

### 6.7.1 Behavior in standard operation

The behavior of the servo amplifier always depends on the current setting of a number of different parameters (e.g., ACTFAULT, VBUSMIN, VELO, STOPMODE, etc.; see online help). The diagram below illustrates the correct functional sequence for switching the servo amplifier on and off.

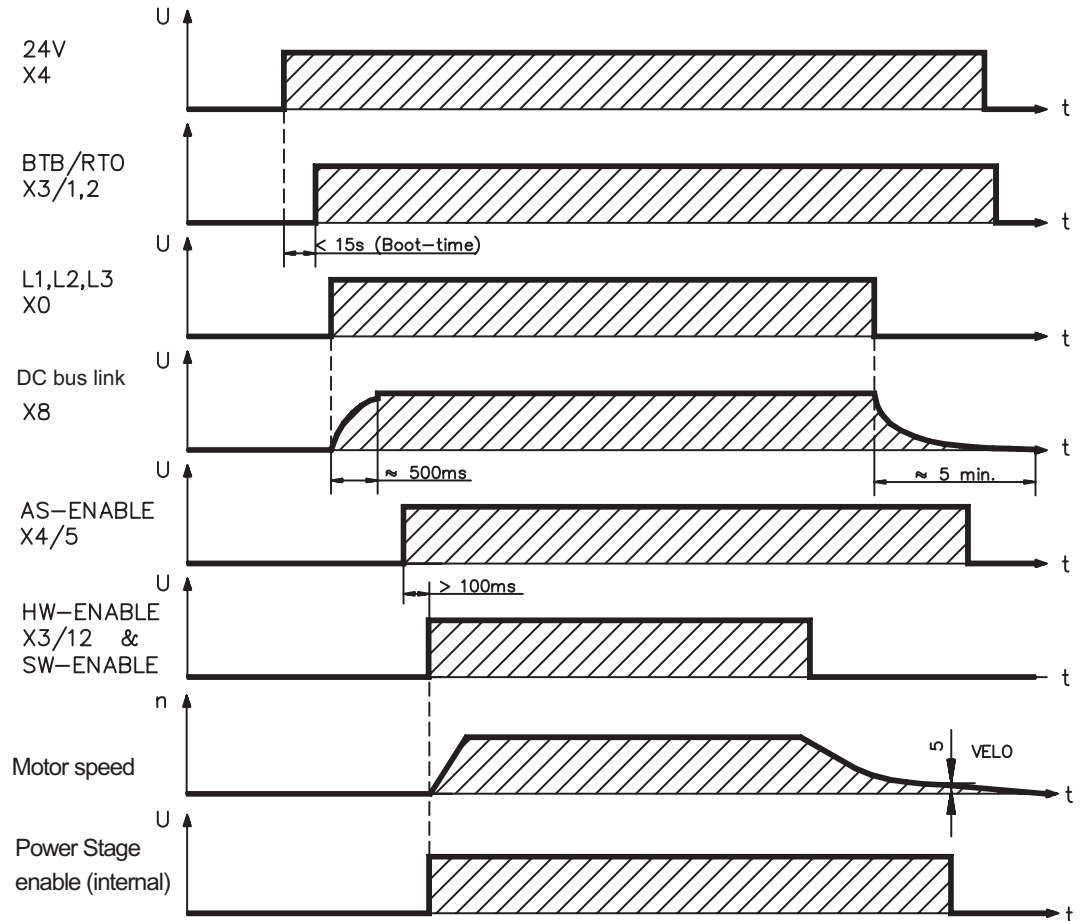

Devices which are equipped with a selected "Brake" function use a special sequence for switching off the output stage ( $\Rightarrow$  p.25).

The built-in restart lock -AS- can be used to switch off the drive, so that personnel safety is ensured at the drive shaft ( $\Rightarrow$  p. 36).

6.7.2 Behavior in the event of an error (with standard setting)

The behavior of the servo amplifier always depends on the current setting of a number of different parameters (e.g., ACTFAULT, VBUSMIN, VELO, STOPMODE, etc.; see online help). The diagram shows the startup procedure and the procedure that the internal control system follows in the event of one or more electrical supply phases failing, assuming that the standard parameter settings apply.

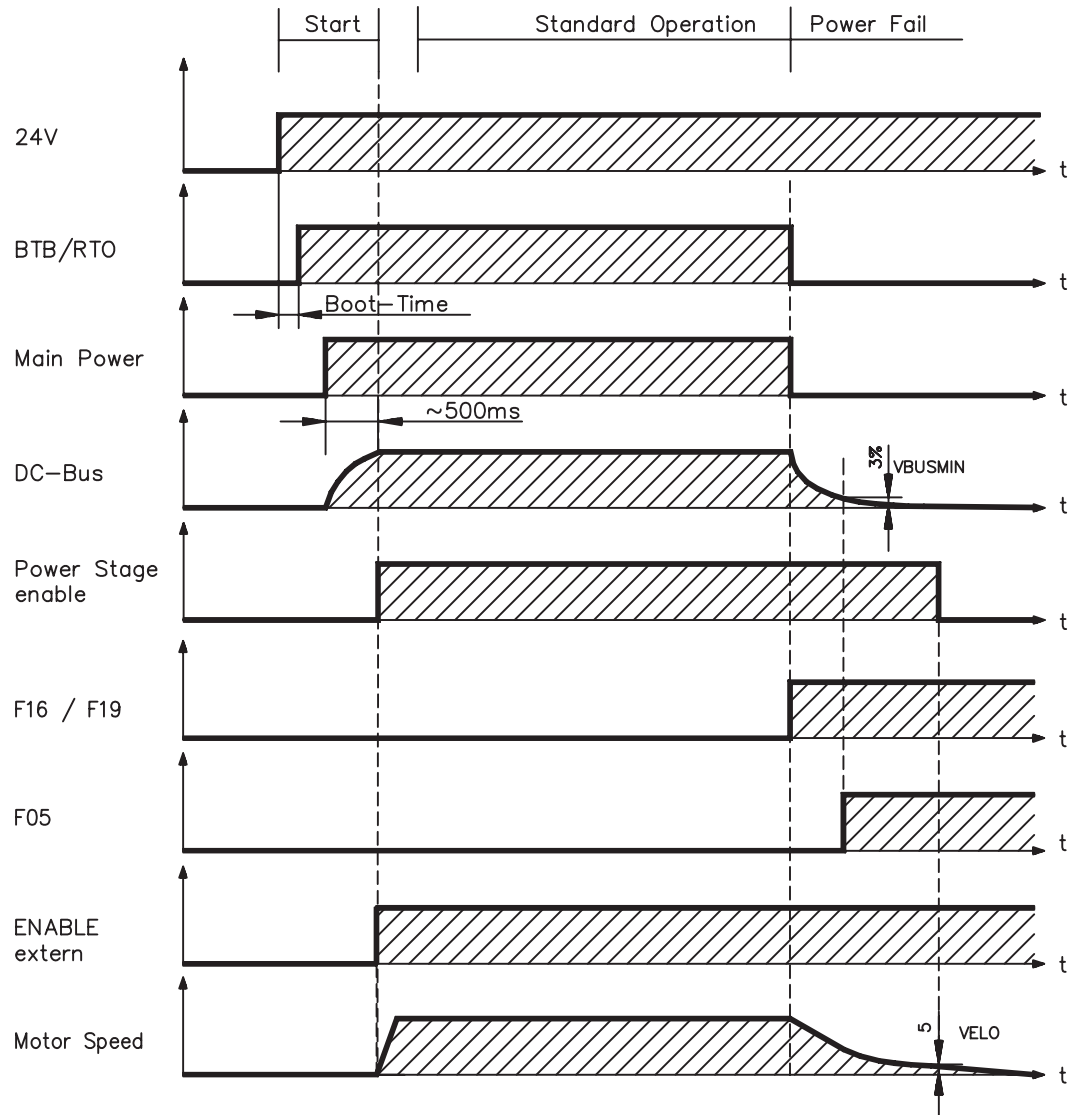

(F16/F19 = error messages Mains BTB /input phase, F05 = error message Undervoltage)

Even if there is no intervention from an external control system (in the example, the ENABLE signal remains active), the motor is immediately braked using the emergency stop ramp if an input phase error is detected and assuming that no changes have been made to the factory setting (ACTFAULT=1).

## 6.8 Stop- / Emergency Stop- Function to EN 60204



With the personnel safe, TÜV-approved restart lock -AS- (see page 36 onwards) the drive can be secured on standstill (torque-free) using its internal electronics so that even when power is being supplied, the drive shaft is protected against unintentional restart (Category 3, in accordance with EN954-1).

### 6.8.1 Stop: Standards

The Stop function is used to shut down the machine in normal operation. The Stop functions are defined by EN 60204.

**Category 0:** Shut-down by immediate switching-off of the energy supply to the drive machinery (i.e. an uncontrolled shut-down);

**Category 1:** A controlled shut-down, whereby the energy supply to the drive machinery is maintained to perform the shut-down, and the energy supply is only interrupted when the shut-down has been completed;

**Category 2:** A controlled shut-down, whereby the energy supply to the drive machinery is maintained.



**The parameters “STOPMODE” and “ACTFAULT” must be set to 1 in order to implement the stop categories. If necessary, change the parameters via the terminal screen of the setup software and store the data in the EEPROM.**

The Stop Category must be determined by a risk evaluation of the machine. In addition, suitable means must be provided to guarantee a reliable shut-down.

Category 0 and Category 1 Stops must be operable independently of the operating mode, whereby a Category 0 Stop must have priority. Stop functions must be implemented by **disconnection** of the appropriate circuitry, and have priority over assigned start functions.

If necessary, provision must be made for the connection of protective devices and lock-outs. If applicable, the Stop function must signal its status to the control logic. A reset of the Stop function must not create a hazardous situation.

## 6.8.2 Emergency Stop: Standards

The emergency Stop function is used for the **fastest possible shut-down** of the machine in a dangerous situation. The Emergency Stop function can be triggered by the actions of a single person. It must be fully functional and available at all times. The user must not have to work out how to operate this mechanism.

The Emergency Stop function is defined by EN 60204.

**In addition** to the requirements for Stop, the emergency Stop must fulfil the following requirements:

- emergency stop must have priority over all other functions and controls in all operating situations;
- the energy supply to any drive machinery that could cause dangerous situations must be switched off as fast as possible, without causing any further hazards (e.g. by using mechanical latching devices that do not require an external supply of energy, by counter-current braking in Stop Category 1);
- the reset must not initiate a restart.

If necessary, provision must be made for the additional connection of emergency stop devices (see EN 60204, "Requirements for emergency stop devices"). The Emergency Stop must be effective as a stop of either Category 0 or Category 1.

The Emergency Stop Category must be determined by a risk evaluation of the machine.

### Category 0

Only hard-wired, electromechanical components may be used for the Category 0 Emergency Stop function. It must not be triggered using switching logic (hardware or software), by transferring commands via a communication network, or via a data link.

The drive must be shut down using an electromechanical circuit. If the connected servo motor has an integrated brake, this must always be controlled by an electromechanical circuit as well.

### Category 1

With the Category 1 Emergency Stop function, there must be absolute certainty in terms of the power supply for the machine drives being switched off (i.e., secured) using electromechanical components. Additional Emergency Stop equipment may be connected. Bringing the motor to a standstill by interrupting the mains supply and using controlled electronic braking. The 24 V supply for the servo amplifier must remain constant. The issue of which circuit should be used is highly dependent on the requirements of the application at hand.

In most servo motors a brake has only the function of a holding brake. To ensure an emergency stop function, the braking torque that is required must be checked. If the holding brake fulfills the dynamic requirements, it must be taken into account that this application will cause increased wear.



**The parameters "STOPMODE" and "ACTFAULT" must be set to 1 in order to implement the stop categories. If necessary, change the parameters via the terminal screen of the setup software and store the data in the EEPROM.**



### 6.8.3 Implementation of the Stop Category 0

Bringing the motor to a standstill by immediately switching off the amplifier power supply (**STOPMODE & ACTFAULT parameters set to 1**). The switching sequence is precisely determined by this circuit in order to avoid undesirable fault messages and servo amplifier failures.

It is not possible to achieve a Category 0 shut-down with the servo amplifier alone, since hard-wired electromechanical components are compulsory for this type of disconnection. A brake that is built into the motor must have an additional electromechanical control circuit, as well as the control through the SERVOSTAR 300, in order to meet Category 0.

Usually a brake in a servo motor only has the function of a holding brake. To ensure an emergency stop function, the braking torque that is required must be checked. If the holding brake fulfills the dynamic requirements, it must be taken into account that this application will cause increased wear.

#### Circuit suggestion

(with EMERGENCY STOP Category 0, control function with contactor relays)

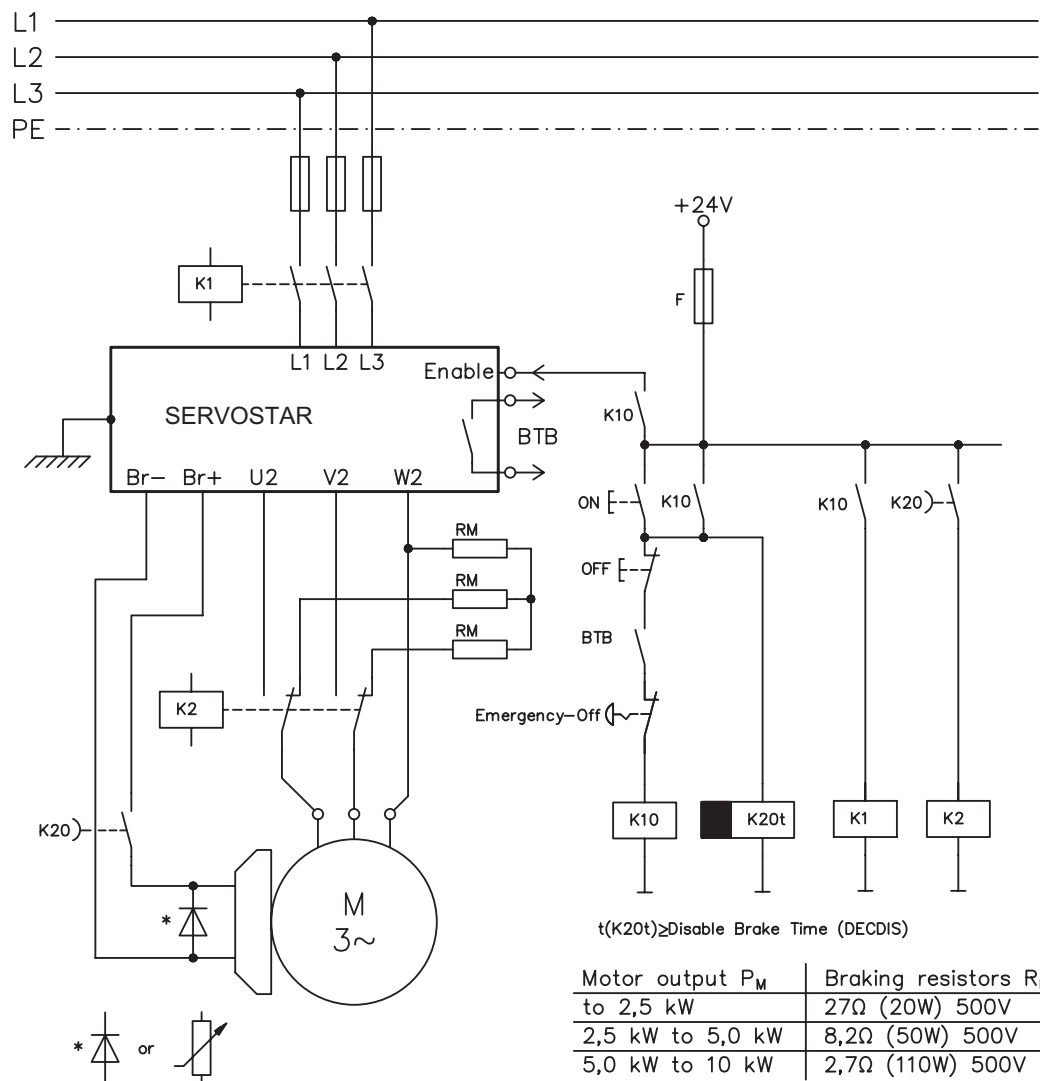

$$P_M = \frac{M_0 * n_n}{9550}$$

$P_M$  : Motor output [kW]  
 $M_0$  : Stall torque [Nm]  
 $n_n$  : Rated speed [1/min]

### 6.8.4 Implementation of the Stop Category 1

Bringing the motor to a standstill by interrupting the mains supply and using controlled electronic braking (**STOPMODE & ACTFAULT parameters set to 1**). The 24 V supply for the SERVOSTAR must remain constant.

The drive is braked in a controlled manner during the stopping (disabling) procedure. If the speed VEL0 (see sequence diagram in chapter 6.3) is undershot, the holding brake is applied and the output stage is disabled.

As soon as two separate time periods (set at the time relay) have elapsed, the mains supply and the holding brake are electrically isolated.

**NOTICE** Should an internal SERVOSTAR 300 fault occur, the motor is forced to a standstill once K20 drops out. Make sure, that the machinery cannot be damaged by forced braking. Forced braking with the built-in motor holding brake can damage the brake.

#### Circuit suggestion

(with EMERGENCY STOP Category 1, control function with contactor relays)

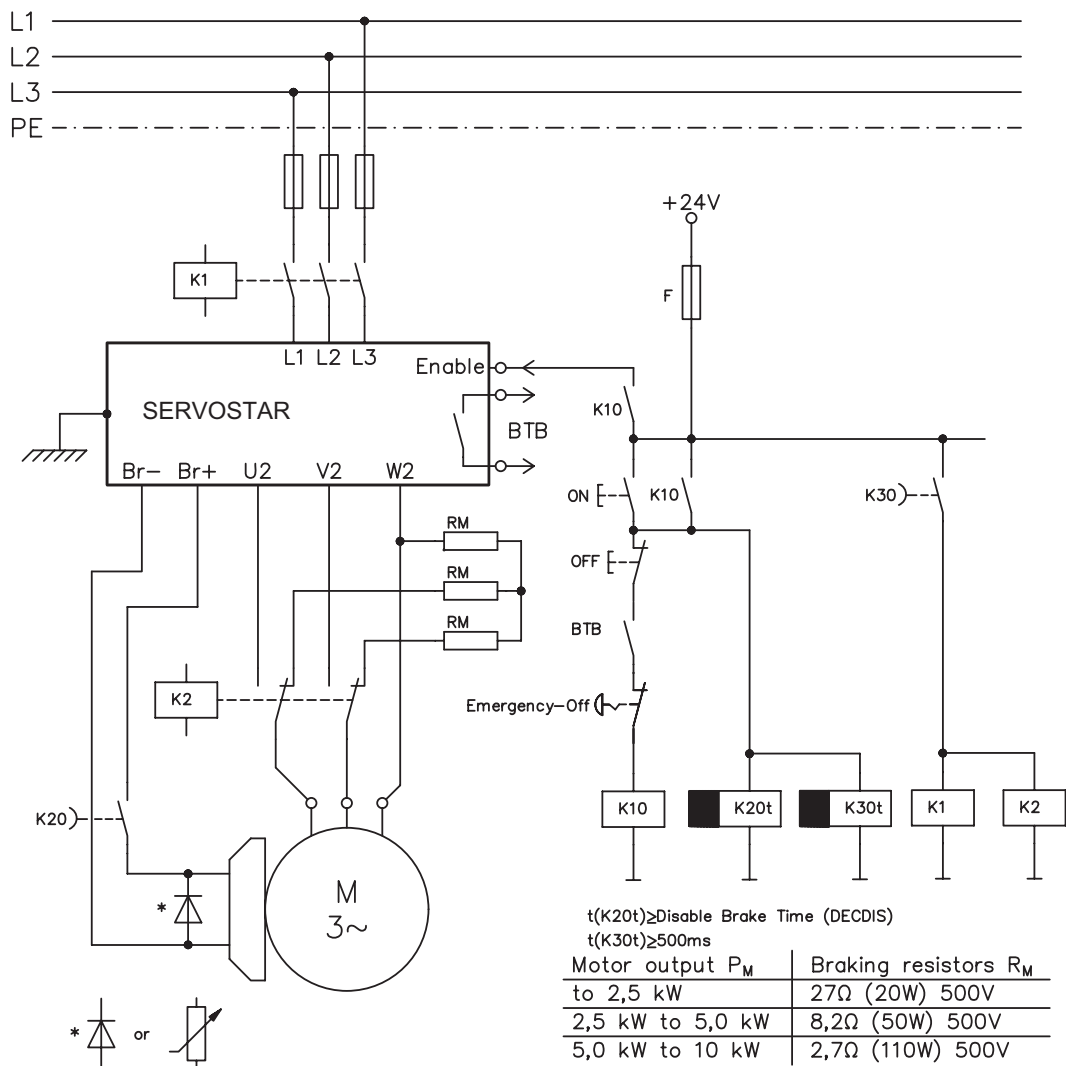

$$P_M = \frac{M_0 * n_n}{9550}$$

P<sub>M</sub> : Motor output [kW]  
M<sub>0</sub> : Stall torque [Nm]  
n<sub>n</sub> : Rated speed [1/min]

6.8.5 Implementation of the Stop Category 2

The machine receives an operational stop (disable) command and brakes the drive using the set braking ramp (**STOPMODE & ACTFAULT parameters set to 1**).

The drive is braked in a controlled manner during the stopping (disabling) procedure. If the speed VEL0 (see sequence diagram in chapter 6.3) is undershot, the holding brake is applied and the output stage is disabled. In this case, there is no interruption of the electrical supply.

If the electrical supply is switched off, not only will the controlled braking procedure be performed, but the mains supply and the holding brake will also be electrically isolated following a time period set at the time relay.

**Circuit suggestion**

(with EMERGENCY STOP Category 1, control function with contactor relays)

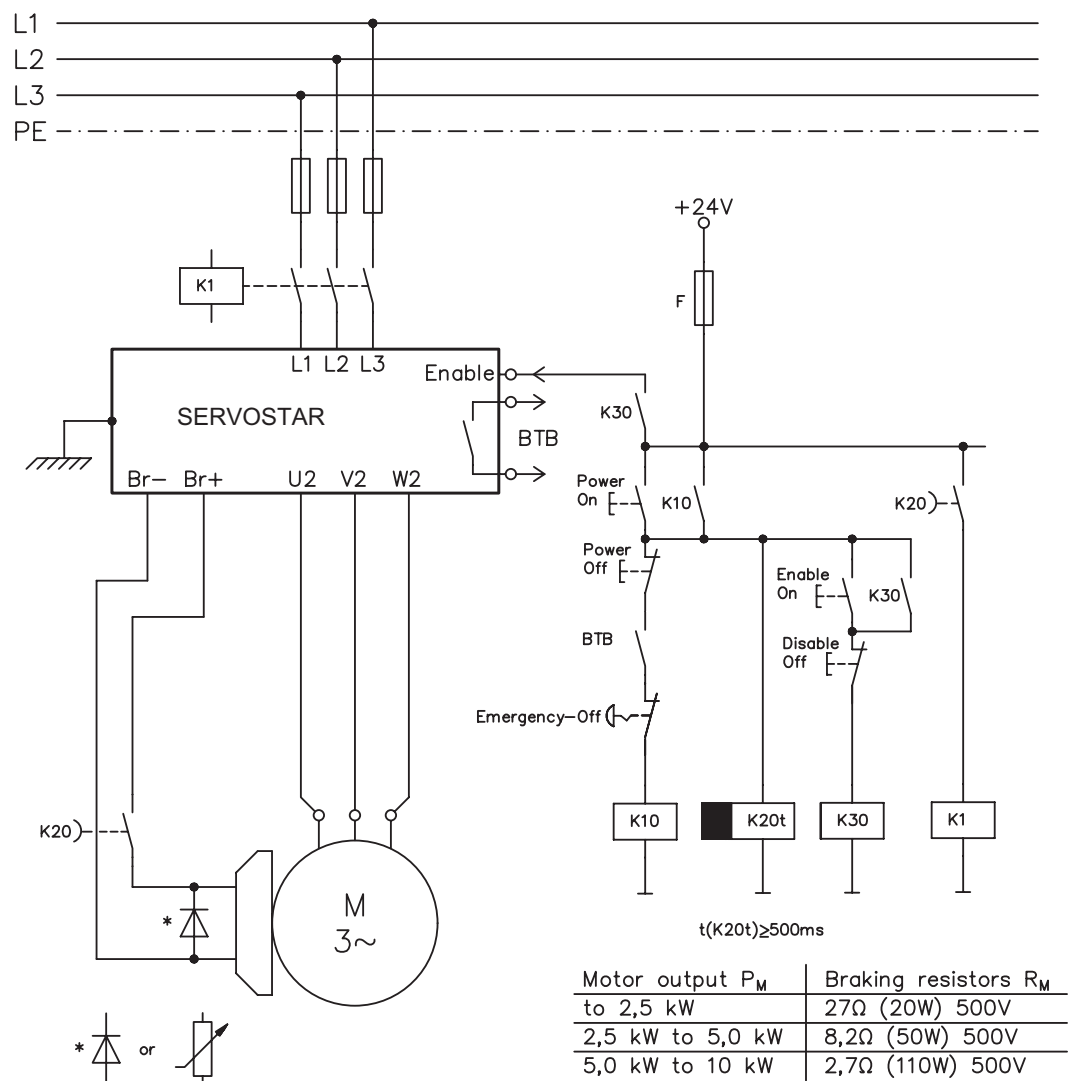

$$P_M = \frac{M_0 * n_n}{9550}$$

P<sub>M</sub> : Motor output [kW]  
 M<sub>0</sub> : Stall torque [Nm]  
 n<sub>n</sub> : Rated speed [1/min]

## 6.9 Personnel safe restart lock -AS-

A frequently required application task is the protection of personnel against the restarting of drives. This can be achieved by an electronic inhibit or with mechanical elements (positively driven relay contacts).

When positively driven relay contacts were used, either the net contactor in the mains supply circuit switched off or the motor was disconnected from the servo amplifier by an additional contactor.

The disadvantages of this method are :

- the DC bus link has to be charged up again at restart
- wear on the contacts of the contactors, caused by switching under load
- extensive wiring required, with additional switching components

The restart lock -AS- avoids these disadvantages.

The conceptual examination of the function "safe stop" (called restart lock AS in the following) was accomplished by the BG-Institute for Occupational Safety and Health and the classification in category 3 according to EN 954-1 was confirmed.

### Advantages of the restart lock -AS- :

- the DC bus link remains charged up, since the mains supply line remains active
- only low voltages are switched, so there is no contact wear
- very little wiring is required
- the functionality and the personnel safety when using the circuit recommendations in this documentation have been approved by the Trade Liability Association.

### 6.9.1 Safety instructions



**If the restart lock -AS- is automatically activated by a control system, then make sure that the output of the control is monitored for possible malfunction. This can be used to prevent a faulty output from unintentionally activating the restart lock -AS-. Since the restart lock is a single-channel system, erroneous engaging will not be recognized.**

### NOTICE

Keep to the following functional sequence when the restart lock -AS- is used :

1. Brake the drive in a controlled manner (speed setpoint = 0V)
2. When speed = 0 rpm, disable the servo amplifier (enable = 0V)
3. If there is a suspended load, block the drive mechanically
4. Activate the restart lock -AS-



Observe the chapter "use as directed" for the restart lock -AS- (⇒ p. 37)

### 6.9.2 Use as directed

The restart lock -AS- is **exclusively** intended to provide safety for personnel, by preventing the restart of a system. To achieve this personnel safety, the wiring of the safety circuits must meet the safety requirements of EN60204, EN12100 and EN 954-1 category 3.

The -AS- restart lock must **only** be activated when the motor is no longer rotating (set-point = 0V, speed = 0rpm, enable = 0V).

**⚠ WARNING** Drives with a suspended load must have an additional safe mechanical blocking (e.g. by a motor-holding brake). The amplifier cannot hold the load when -AS- is active. That could result in serious injury.

The -AS- restart lock must **not** be used if the drive is to be made inactive for the following reasons :

1. - cleaning, maintenance and repair operations  
- long inoperative periods  
In such cases, the entire system should be disconnected from the supply by the personnel, and secured (main switch).
2. - emergency-stop situations  
In an emergency-stop situation, the main contactor is switched off (by the emergency-stop button).

### 6.9.3 Technical data and pinning

<b>Input voltage</b>	20 V..30 V
<b>Input current</b>	40 mA – 75 mA (leff)
<b>Peak current</b>	220 mA (Is)

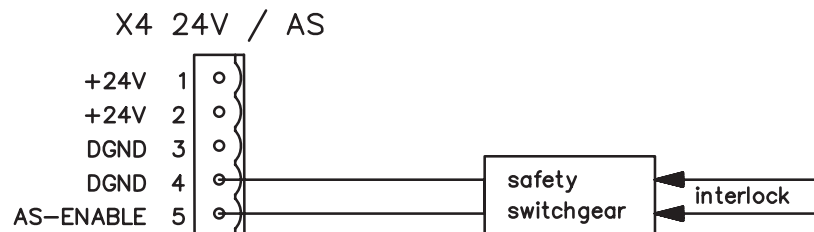

### 6.9.4 Enclosure

Since the servo amplifier meets enclosure IP20, you must select the environment ensuring a safe operation of the servo amplifier. The enclosure must meet IP54 at least.

### 6.9.5 Wiring

When using wiring leads outside the demanded enclosure (IP54), the cables must be laid durably (firmly), protected from outside damage (e.g. laying in a cable duct), in different sheathed cables or protected individually by grounding connection.

Wiring remaining within the demanded enclosure must meet the requirements of the standard EN 60204-1.

**6.9.6 Functional description**

When restart lock -AS- is not needed, then the input AS-ENABLE must be connected directly with +24VDC. The restart lock is then passed by and cannot not be used.

In case of use of the restart lock the input AS Enable must be connected to the exit of a security control or a safety relay, which meets at least to the requirements of the category 3 after EN 954-1 (see the connection diagram on page 40).

Possible states of the servo amplifier in connection with restart lock -AS-:

AS-ENABLE	ENABLE	Display	Motor has torque	Safety cat. 3
0 V	0 V	-S-	no	yes
0 V	+24 V	F27	no	yes
+24 V	0 V	normal status e.g. 06	no	no
+24 V	+24 V	normal status e.g. E06	yes	no

If the restart lock is engaged during operation by separating input AS ENABLE from 24 VDC, the motor runs down out of control and the servo amplifier displays the error F27.

**⚠ CAUTION** There is no possibility of braking the drive controlled. If a controlled braking before the use of the restart lock is necessary, the drive must be braked and the input AS-ENABLE has to be separated from +24 VDC time-delayed.

**⚠ CAUTION** The restart lock -AS- does not provide an electrical separation from the power output. If access to the motor power terminals is necessary, the servo amplifier must be disconnected from mains supply considering the discharging time of the intermediate circuit.

When restart lock is a single-channel system, erroneous engaging will not be recognized. When wiring the input AS-ENABLE within one enclosure it must be paid attention to the fact that the used cables and the enclosure meet the requirements of EN 60204-1.

If the wiring leads outside the demanded enclosure, the cables must be laid durably (firmly), and protected from outside damage.

### 6.9.6.1 Signal diagram (sequence)

The diagram shows how to use restart lock -AS- to ensure a safe stop of the drive and error free operation of the servo amplifier.

1. Brake the drive in a controlled manner (speed setpoint = 0 V)
2. When speed = 0 rpm, disable the servo amplifier (Enable = 0 V)
3. Activate the restart lock -AS- (AS-Enable = 0 V)

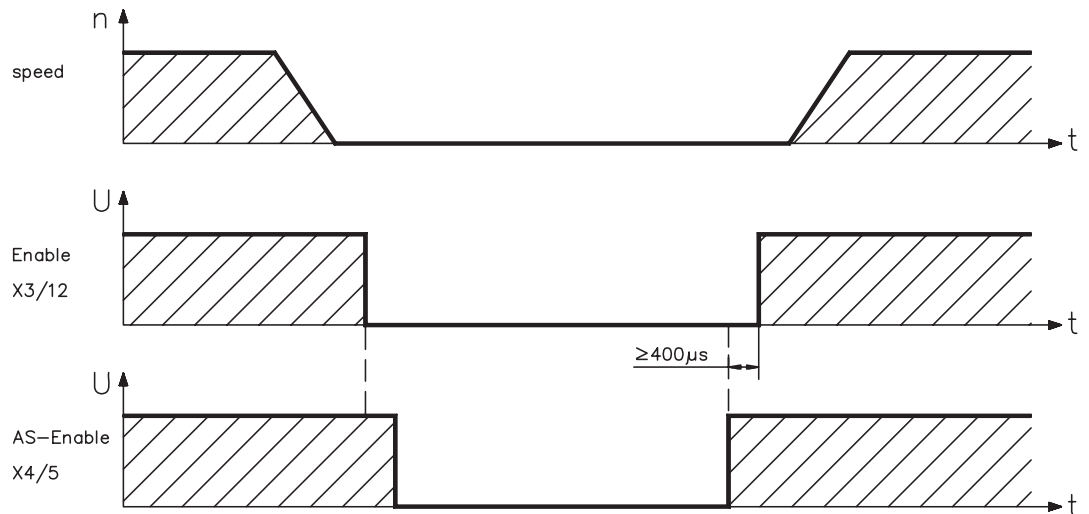

**⚠ WARNING** Suspended loads can set themselves to motion on motors without brake, because the motor loses all torque when restart lock -AS- is engaged (AS Enable open and/or 0 V).

6.9.6.2 Control circuit

The example shows a circuit diagram with two separated work areas connected to one emergency stop circuit. For each work area individually "safe stop" of the drives is switched by a protective screen.

The safety switchgears used in the example are manufactured by Pilz and fulfill at least the safety category 3 according to EN 954-1. Further information to the safety switchgears is available from Pilz. The use of safety switchgears of other manufacturers is possible, if these also fulfill the safety category 3 according to EN 954-1.

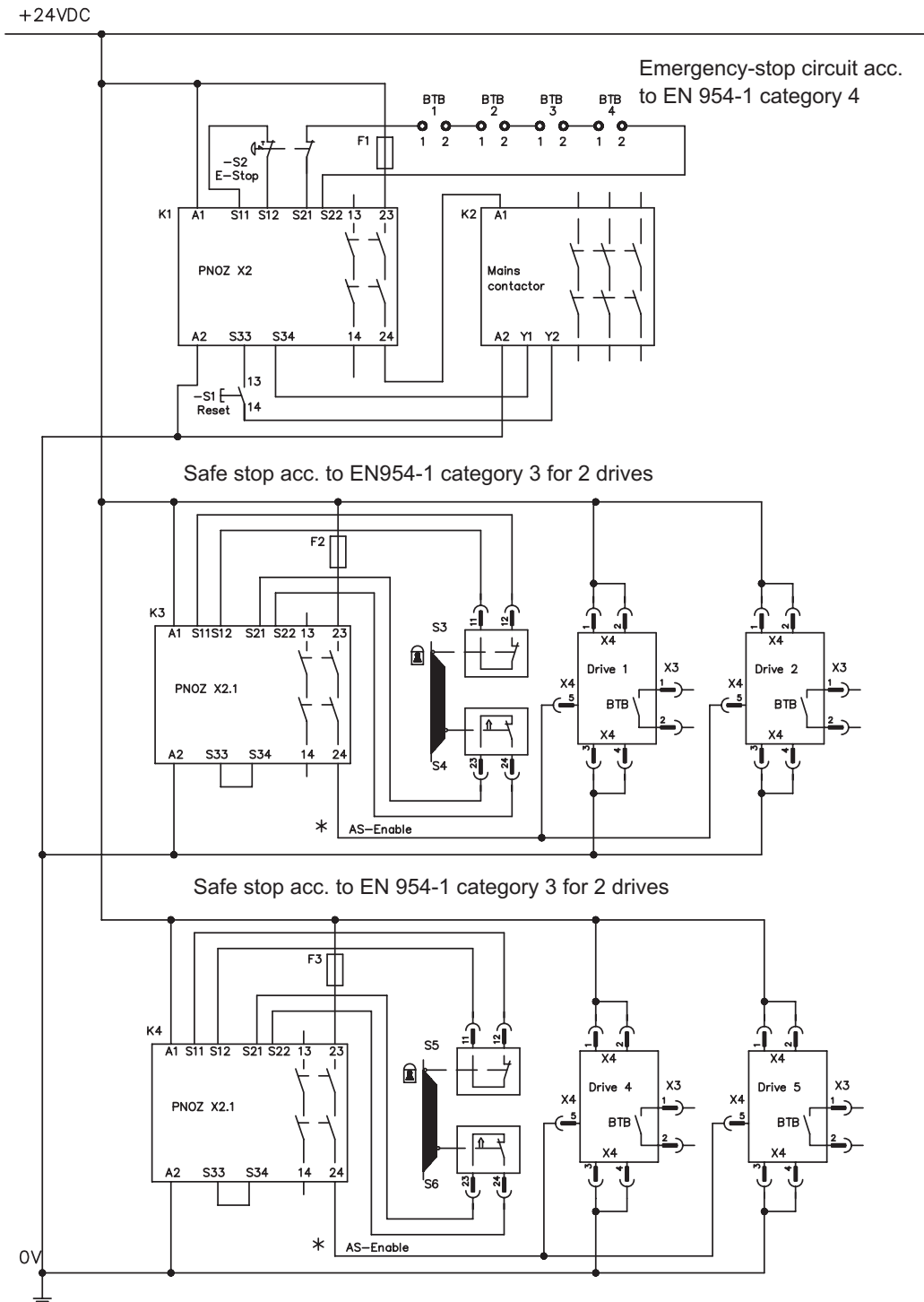

Consider the wiring instructions on page 37.



### 6.9.6.3 Functional test

**CAUTION** With initial starting and after each interference into the wiring of the drive or after exchange of one or several components of the drive the function of the restart lock must be tested.

#### 1. Method:

1. Stop drive, with setpoint 0V, keep servo amplifier enabled.

**DANGER: Do not enter hazardous area!**

2. Activate the restart lock -AS- e.g. by opening protective screen. (voltage at X4/5 0 V)

Now the BTB/RTO contact opens, the net contactor releases and the servoamplifier displays error F27.

#### 2. Method:

1. Stop all drives, with setpoint 0V, disable servo amplifier.

2. Activate the restart lock -AS- e.g. by opening protective screen. (voltage at X4/5 0 V)

Now the servo amplifier displays -S-.

### 6.9.6.4 Mains supply circuit

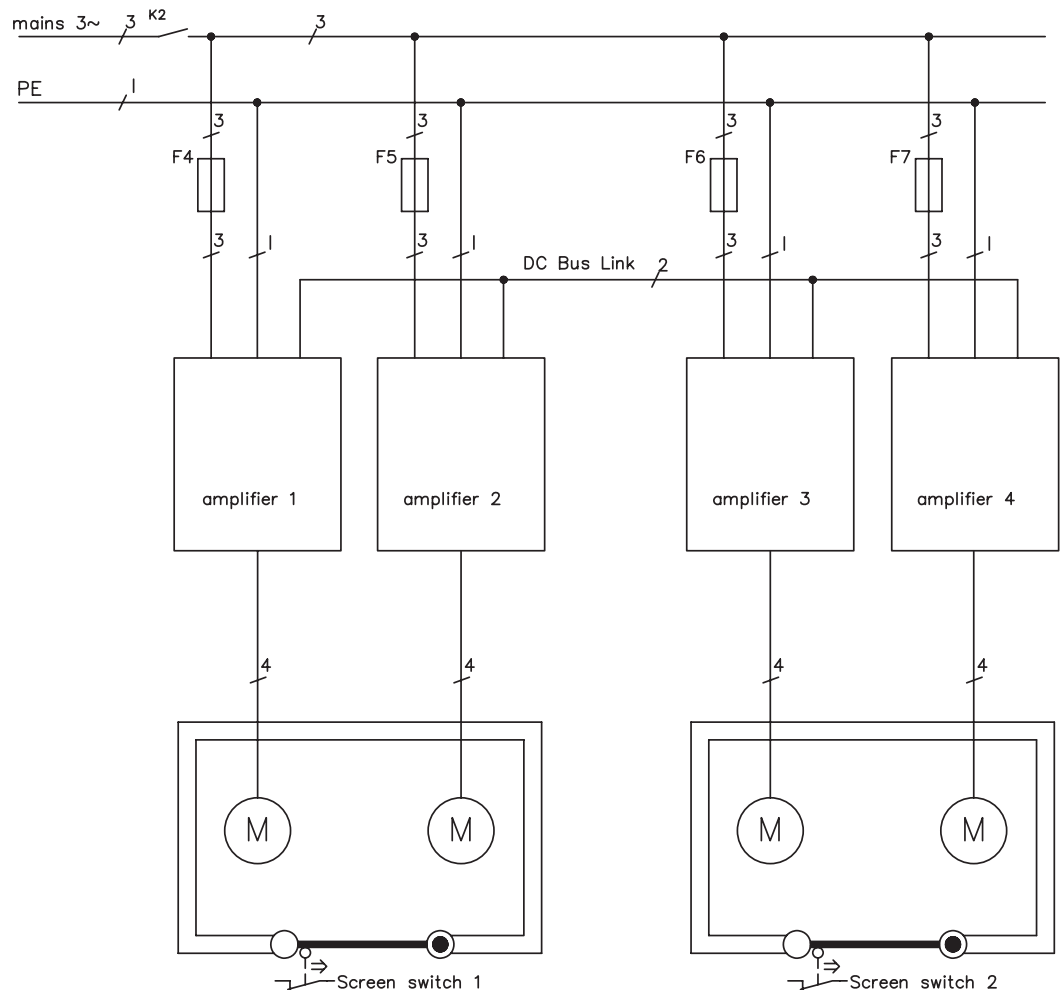

**6.10 Shock-hazard protection**

**6.10.1 Leakage current**

Leakage current via the PE conductor results from the combination of equipment and cable leakage currents. The leakage current frequency pattern comprises a number of frequencies, whereby the residual-current circuit breakers definitively evaluate the 50Hz current. For this reason, the leakage current cannot be measured using a conventional multimeter.

As a rule of thumb, the following assumption can be made for leakage current on our low-capacity cables at a mains voltage of 400 V, depending on the clock frequency of the output stage:

$$I_{leak} = n \times 20mA + L \times 1mA/m \text{ at 8kHz clock frequency at the output stage}$$

$$I_{leak} = n \times 20mA + L \times 2mA/m \text{ at a 16kHz clock frequency at the output stage}$$

(where  $I_{leak}$ =leakage current,  $n$ =number of amplifiers,  $L$ =length of motor cable)

At other mains voltage ratings, the leakage current varies in proportion to the voltage.

Example: 2 x servo amplifiers + a 25m motor cable at a clock frequency of 8kHz:  
 2 x 20mA + 25m x 1mA/m = 65mA leakage current.



**Since the leakage current to PE is more than 3.5 mA, in compliance with EN50178 the PE connection must either be doubled or a connecting cable with a cross-section >10mm<sup>2</sup> must be used. Use the PE terminals and the PE bolt in order to fulfil this requirement.**

The following measures can be used to minimise leakage currents.

- Reduce the length of the engine cable
- Use low-capacity cables (see p.53)
- Remove external EMC filters (radio-interference suppressors are integrated)

**6.10.2 Residual current protective device (RCD)**

In conformity with IEC 60364-4-41 – Regulations for installation and EN 60204 – Electrical equipment of machinery, residual current protective devices (called RCD below) can be used provided the requisite regulations are complied with.

The SERVOSTAR 300 is a 3-phase system with a B6 bridge. Therefore, **RCDs which are sensitive to all currents** must be used in order to detect any D.C. fault current. Refer to chapter 6.10.1 for the rule of thumb for determining the leakage current.

Rated residual currents in the RCD

<b>10 -30 mA</b>	Protection against "indirect contact" (personal fire protection) for stationary and mobile equipment, as well as for "direct contact".
<b>50 -300 mA</b>	Protection against "indirect contact" (personal fire protection) for stationary equipment



**Recommendation: In order to protect against direct contact (with motor cables shorter than 5 m) we recommend that each servo amplifier be protected individually using a 30mA RCD which is sensitive to all currents.**

If you use a selective RCD, the more intelligent evaluation process will prevent spurious tripping of the RCD.

### 6.10.3 Isolating transformers

When protection against indirect contact is absolutely essential despite a higher leakage current, or when an alternative form of shock-hazard protection is sought, the SERVOSTAR 300 can also be operated via an isolating transformer (schematic connection see p.58).

A ground-leakage monitor can be used to monitor for short circuits.



**Be advised to keep the length of wiring between the transformer and the servo amplifier as short as possible.**

This page has been deliberately left blank.

## 7 Mechanical Installation

### 7.1 Safety Instructions

**⚠ CAUTION** There is a danger of electrical shock by high EMC level which could result in injury, if the servo amplifier (or the motor) isn't properly EMC-grounded. Do not use painted (i.e. non-conductive) mounting plates.

#### NOTICE

Protect the servo amplifier from impermissible stresses. In particular, do not let any components become bent or any insulation distances altered during transport and handling. Avoid contact with electronic components and contacts.

#### NOTICE

The servo amplifier will switch-off itself in case of overheating. Ensure that there is an adequate flow of cool, filtered air into the bottom of the control cabinet, or use a heat exchanger. Please refer to page 24.

#### NOTICE

Don't mount devices, which produce magnetic fields, directly beside the servo amplifier. Strong magnetic fields could directly affect internal components. Install devices which produce magnetic field with distance to the servo amplifiers and/or shield the magnetic fields.

### 7.2 Guide to mechanical installation

The following notes should help you to carry out the mechanical installation.

<b>Site</b>	In a closed control cabinet. Please refer to page 24. The site must be free from conductive or corrosive materials. For the mounting position in the cabinet ⇒ p.46.
<b>Ventilation</b>	Check that the ventilation of the servo amplifier is unimpeded, and keep within the permitted ambient temperature ⇒ p.24. Keep the required space clear above and below the servo amplifier ⇒ p.46.
<b>Assembly</b>	Assemble the servo amplifier and power supply close together, on the conductive, <b>grounded</b> mounting plate in the cabinet.
<b>Grounding Shielding</b>	For EMC-compliant shielding and grounding ⇒ p.57. Ground the mounting plate, motor housing and CNC-GND of the control system. Notes on connection techniques ⇒ p.52.

### 7.3 Assembly

Material: 3 x M5 hexagon socket screws to DIN 912

Tool required : 4 mm Allen key

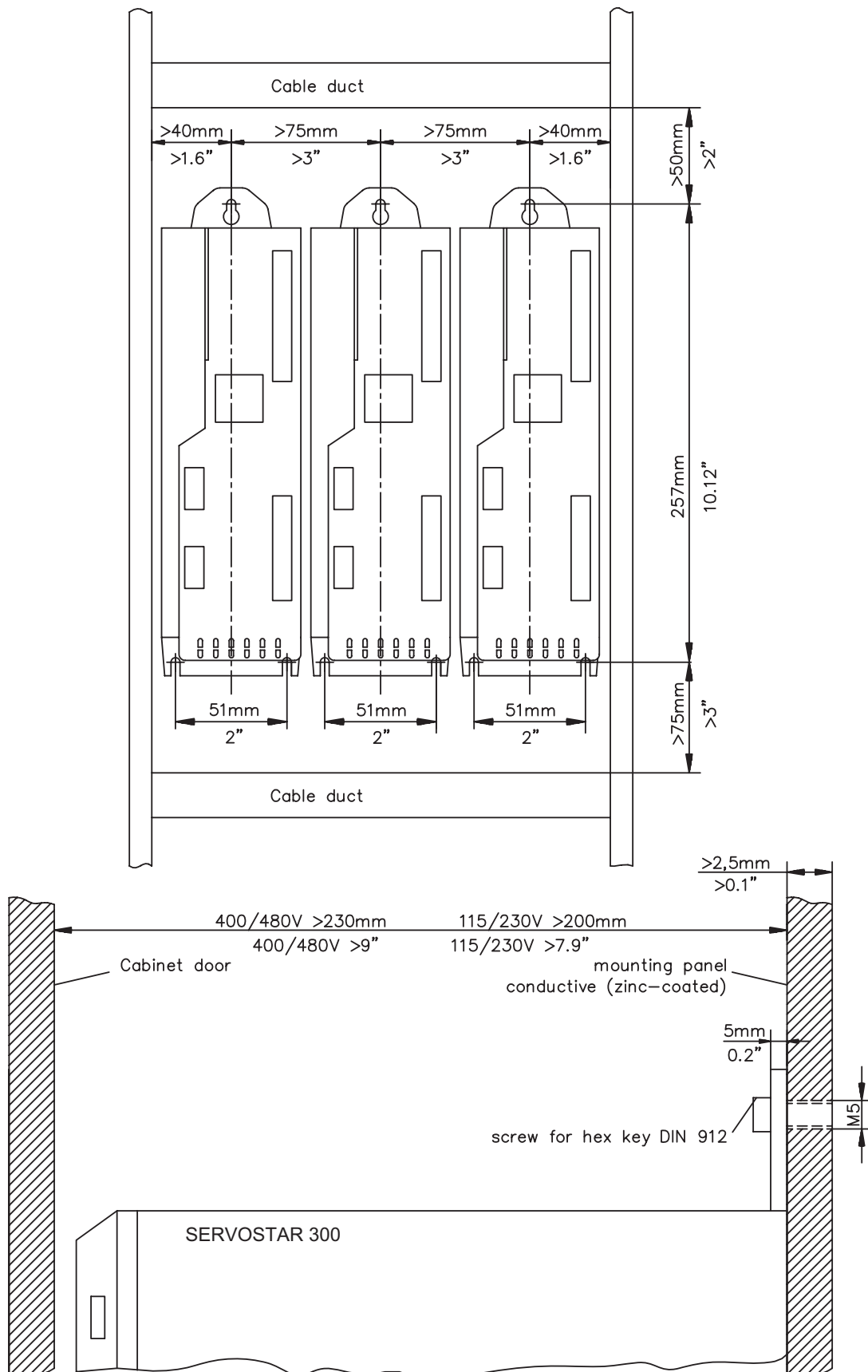

7.4 Dimensions

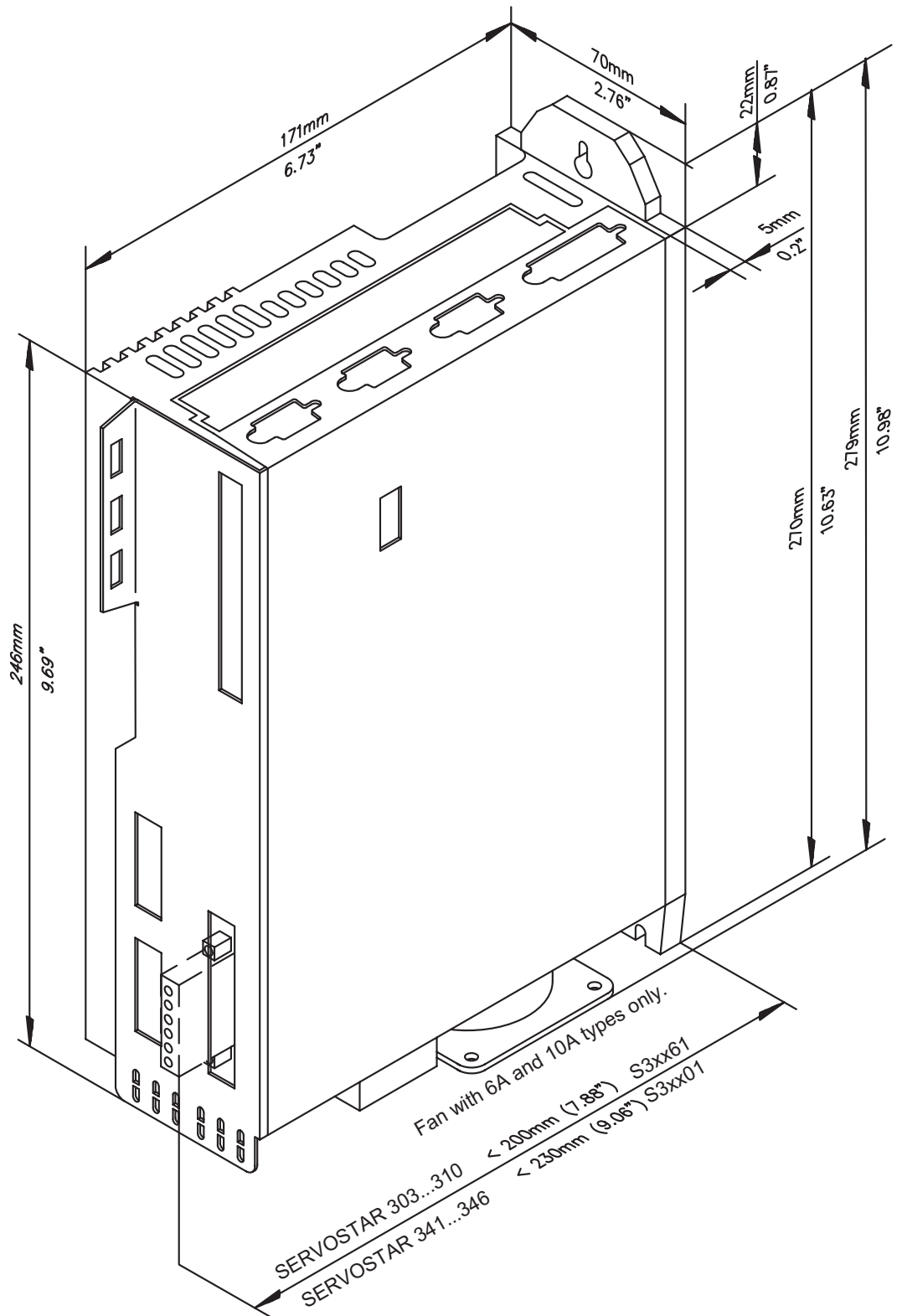

This page has been deliberately left blank.



## 8 Electrical installation

### 8.1 Safety Instructions

**⚠ DANGER** Never undo any electrical connections to the servo amplifier while it is live. There is a danger of electrical arcing with damage to contacts and serious personal injury. Wait at least five minutes after disconnecting the servo amplifier from the main supply power before touching potentially live sections of the equipment (e.g. contacts) or undoing any connections. Capacitors can still have dangerous voltages present up to five minutes after switching off the supply power. To be sure, measure the voltage in the DC Bus link and wait until it has fallen below 40V. Control and power connections can still be live, even if the motor is not rotating.

**NOTICE** Wrong mains voltage, unsuitable motor or wrong wiring will damage the amplifier. Check the combination of servo amplifier and motor. Compare the rated voltage and current of the units. Implement the wiring according to the connection diagram on page 51. Make sure that the maximum permissible rated voltage at the terminals L1, L2, L3 or +DC, -DC is not exceeded by more than 10% even in the most unfavorable circumstances (see EN 60204-1).

**NOTICE** Excessively high external fusing will endanger cables and devices. The fusing of the AC supply input and 24V supply must be installed by the user, best values are given on p.23. Hints for use of Residual-current circuit breakers (FI) ⇒ p.42.

**NOTICE** Correct wiring is the basis for reliable functioning of the servo system. Route power and control cables separately. We recommend a distance of at least 200mm. This improves the interference immunity. If a motor power cable is used that includes cores for brake control, the brake control cores must be separately shielded. Ground the shielding at both ends. Ground all shielding with large areas (low impedance), with metalized connector housings or shield connection clamps wherever possible. Notes on connection techniques can be found on page 52.

**NOTICE** Feedback lines may not be extended, since thereby the shielding would be interrupted and the signal processing could be disturbed. Lines between amplifiers and external brake resistor must be shielded. Install all power cables with an adequate cross-section, as per EN 60204 (⇒ p.24) and use the requested cable material (⇒ p. 53) to reach max. cable length.

**NOTICE** The servo amplifier's status must be monitored by the PLC to acknowledge critical situations. Wire the BTB/RTO contact in series into the emergency stop circuit of the installation. The emergency stop circuit must operate the supply contactor.



It is permissible to use the setup software to alter the settings of the servo amplifier. Any other alterations will invalidate the warranty.

## 8.2 Guide to electrical installation

The following notes should help you to carry out the electrical installation.

**Cable selection** Select cables in accordance with EN 60204 ⇒ p.24.

### Grounding Shielding

For EMC-compliant shielding and grounding ⇒ p.57.  
Ground the mounting plate, motor housing and CNC-GND of the control system. Notes on connection techniques ⇒ p.52.



### Wiring

**Route power leads and control cables separately.**  
**Wire the BTB/RTO contact in series into the emergency stop circuit of the system.**

- Connect the digital control inputs and outputs.
- Connect up AGND (also if fieldbuses are used).
- Connect the analog input source, if required.
- Connect the feedback device.
- Connect the encoder emulation, if required.
- Connect the expansion card  
(see corresponding notes from page 107).
- Connect the motor cable  
Connect shielding to EMC connectors (shield connection) at both ends. Use the motor choke (3YL) if cable > 25 meters.
- Connect motor-holding brake, connect shielding to EMC connector/shield connection at both ends.
- If required, connect the external brake resistor (with fusing).
- Connect the auxiliary supply  
(maximum permissible voltage values ⇒ p.24).
- Connect the main electrical supply  
(maximum permissible voltage values ⇒ p.24).
- Connect the PC (⇒ p.86).

### Final check

- Final check of the implementation of the wiring against the wiring diagrams that have been used.

## 8.3 Wiring

The installation procedure is described as an example. A different procedure may be appropriate or necessary, depending on the application of the equipments. We provide further know-how through **training courses** (on request).

### 8.3.1 Safety instructions

**⚠ DANGER** There is a danger of electrical arcing with serious personal injury. Only install and wire up the equipment when it is not live, i.e. when neither the electrical supply nor the 24 V auxiliary voltage nor the supply voltages of any other connected equipment is switched on.

Take care that the cabinet is safely disconnected (with a lock-out, warning signs etc.). The individual voltages will be switched on for the first time during setup.

**⚠ CAUTION** Only professional staff who are qualified in electrical engineering are allowed to install the servo amplifier.



The ground symbol  $\text{⏏}$ , which you will find in all the wiring diagrams, indicates that you must take care to provide an electrically conductive connection with the largest feasible surface area between the unit indicated and the mounting plate in the control cabinet. This connection is for the effective grounding of HF interference, and must not be confused with the PE-symbol  $\text{⏏}$  (PE = protective earth, safety measure as per EN 60204).



Use the following connection diagrams :

Restart lock -AS-	: page 40
Overview	: page 57
Mains power	: page 59
Motor	: page 62
Feedback	: page 63ff
Electronic Gearing / Master Slave	
Master-Slave	: page 78
Pulse-Direction	: page 79
Encoder Emulation	
ROD (A quad B)	: page 81
SSI	: page 82
Digital and analog inputs and outputs	: page 83ff
RS232 / PC	: page 86
CAN Interface	: page 87
Expansion cards	
I/O-14/08	: page 110
PROFIBUS	: page 111
SERCOS	: page 113
DeviceNet	: page 114
EtherCat	: page 117
SynqNet	: page 119
2CAN	: page 121

### 8.3.2 Shielding connection to the front panel

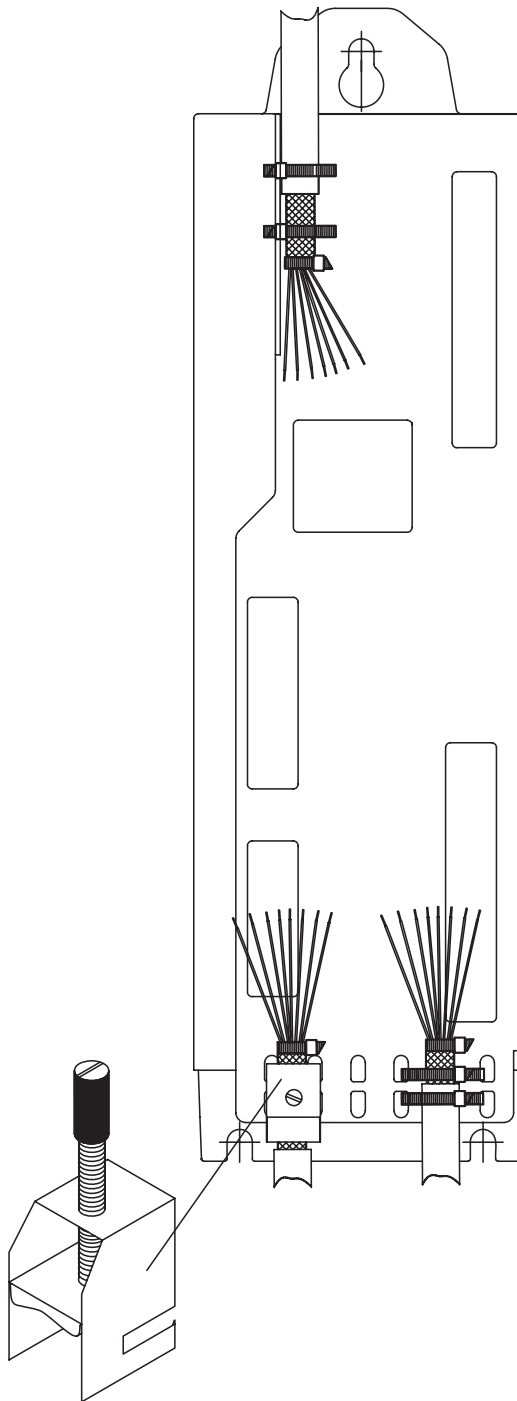

Remove the outside shroud of the cable and the shielding braid on the desired core length. Secure the cores with a cable tie.

Remove the outside shroud of the line on a length from for instance 30mm without damaging the shielding braid.

Pull a cable tie by the slot in the shielding rail on the front panel of the servo amplifier.

Press the shielding of the cable firmly against the front panel with the cable tie.

Use the shield clamp that is delivered with the motor cable for the shield connection of the motor cable. The clamp must be hooked in the lower shroud and guarantees optimal contact between shield and shroud.

### 8.3.3 Technical data for connecting cables

Further information on the chemical, mechanical and electrical characteristics of the cables can be obtained from our customer service.



Observe the rules in the section "Conductor cross-sections" on page 24. To reach the max. permitted cable length, you must use cable material that matches the capacitance requirements listed below.

#### Capacitance (phase to shield)

Motor cable	less than 150 pF/m
Resolver/Encoder cable	less than 120 pF/m

Example: Motor cable

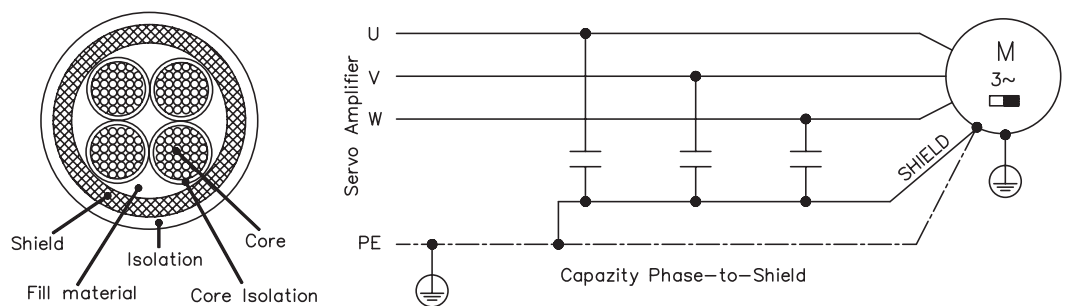

#### Technical data

For a detailed description of cable types and how to assemble them, please refer to the accessories manual.



Motor cables longer than 25m require the use of a motor choke 3YL.

8.4 Components of a servo system

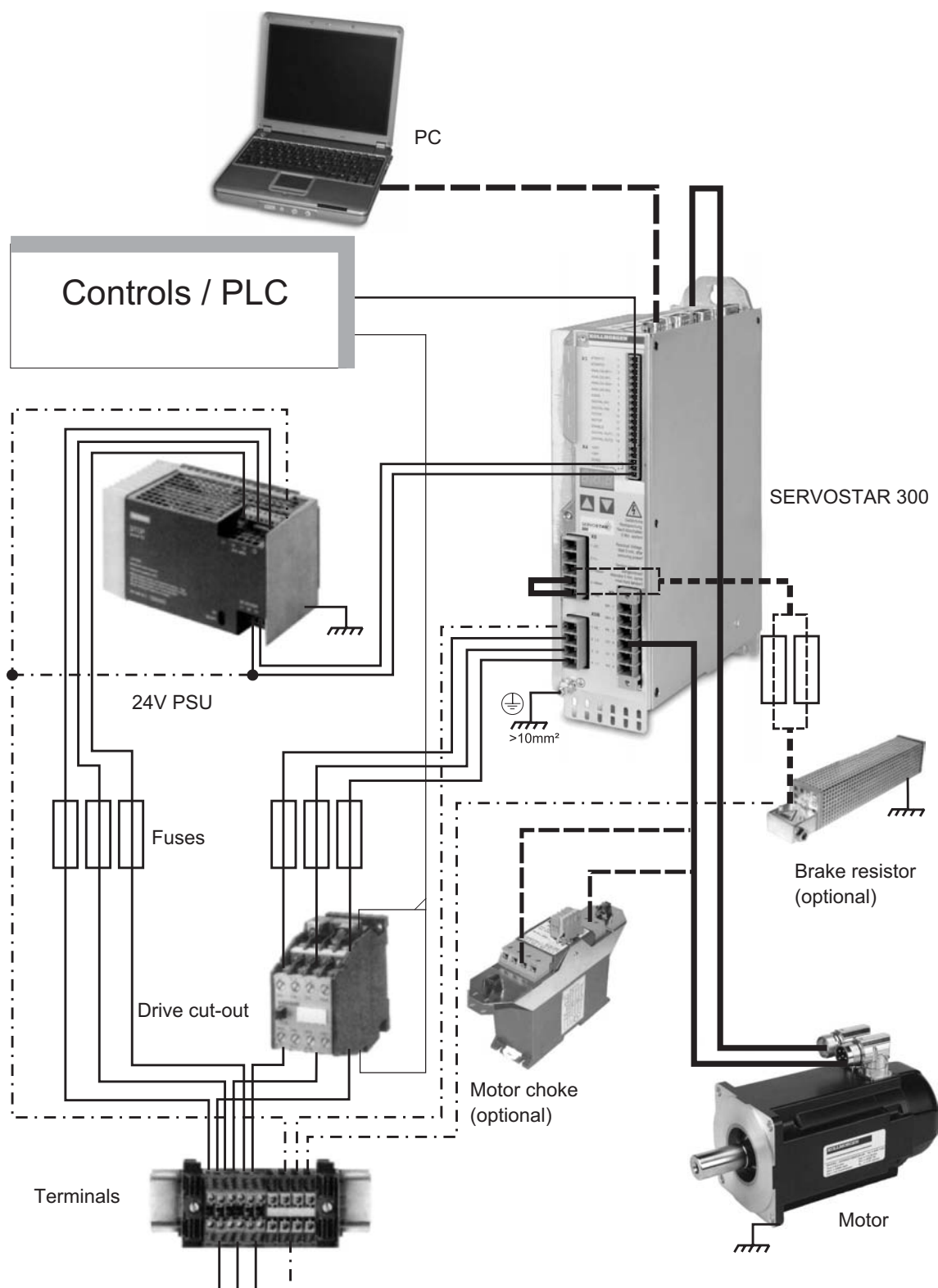

Cables drawn bold are shielded. Electrical ground is drawn with dash-dotted lines. Optional devices are connected with dashed lines to the servo amplifier. The required accessories are described in our accessories manual.

### 8.5 Block diagram

The block diagram below just provides an overview.

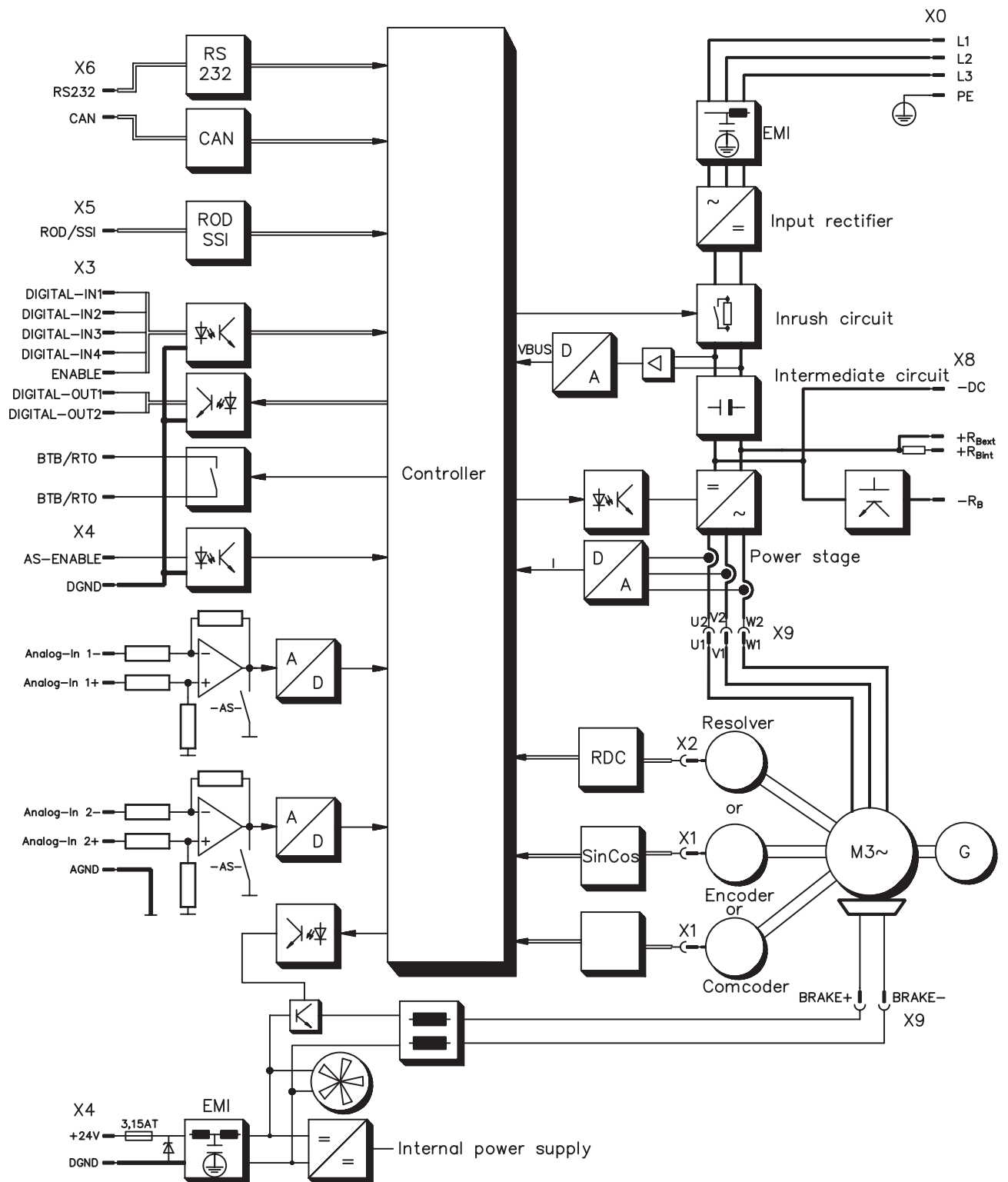

### 8.6 Connector assignments

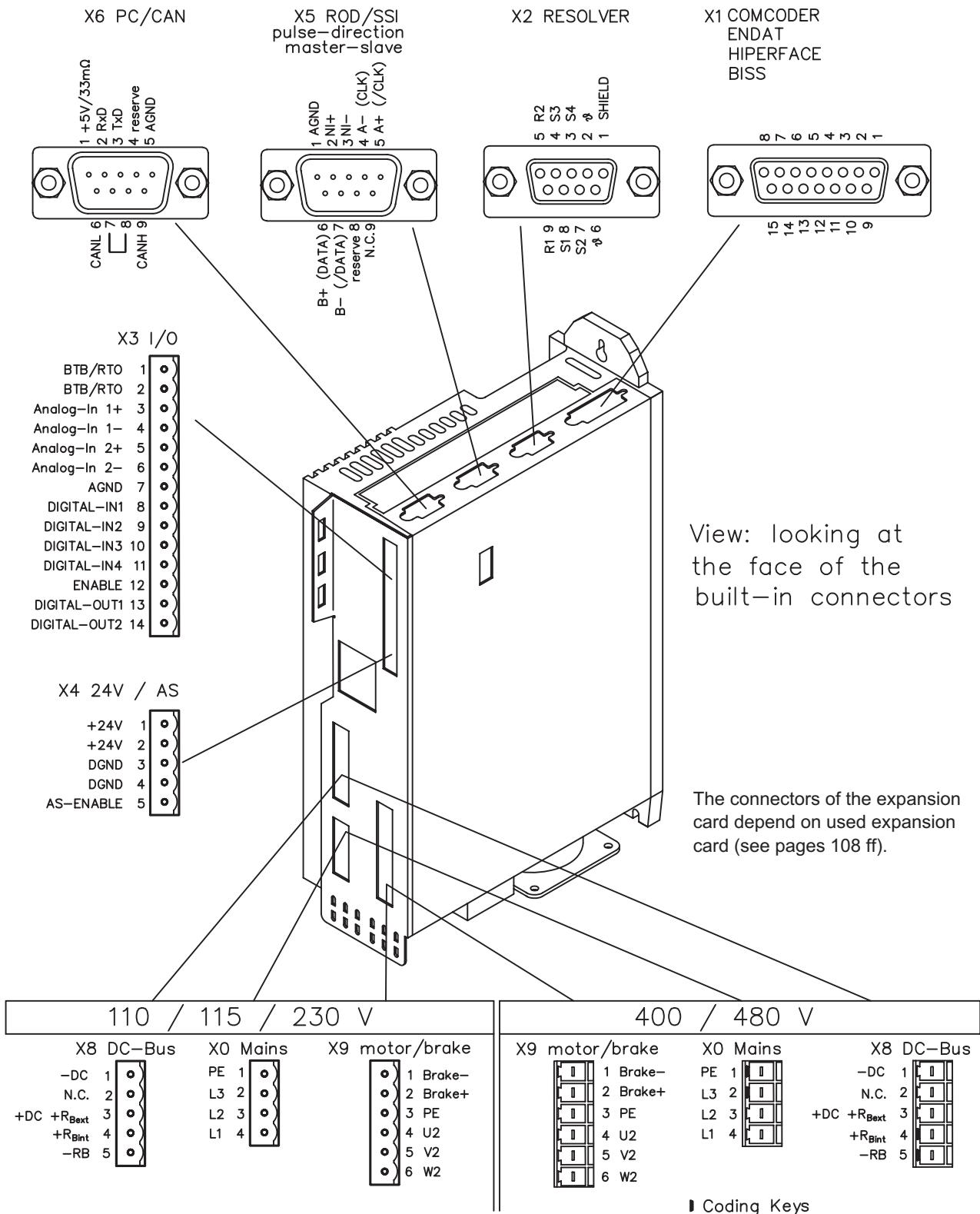



### 8.7 Connection diagram (Overview)

Refer to the Safety Instructions (⇒ p.10) and Use as Directed (⇒ p.11)!

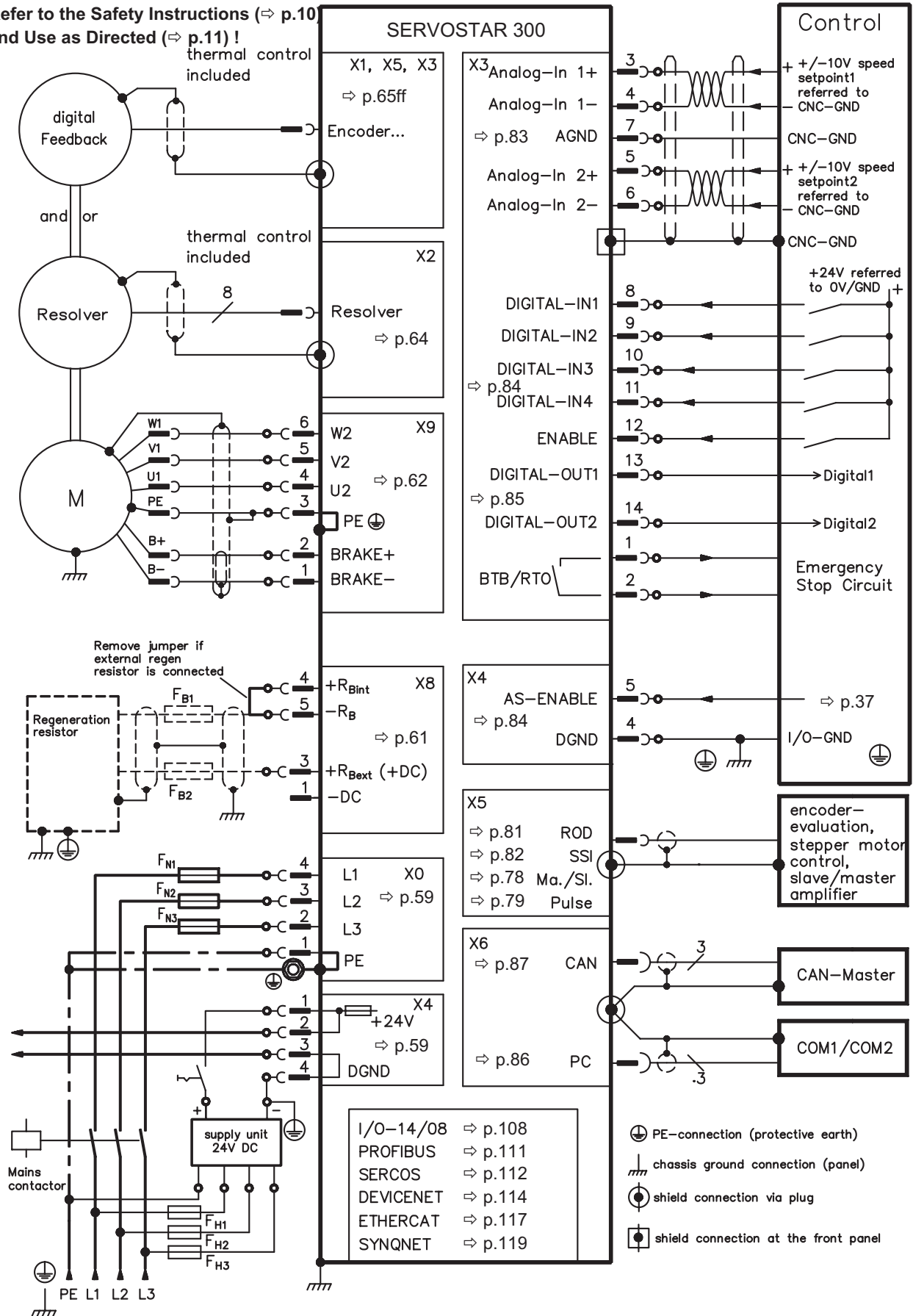

8.8 Electrical supply

8.8.1 Connection to various mains supply networks

**⚠ WARNING** There is a danger of electrical shock with serious personal injury if the servo amplifier isn't properly grounded. An isolating transformer is always required for 400 ... 480V networks that are asymmetrically grounded or not grounded.

**110V** : SERVOSTAR 303-310\*  
**230V** : all types

**400V / 480V** : SERVOSTAR 341-346\*

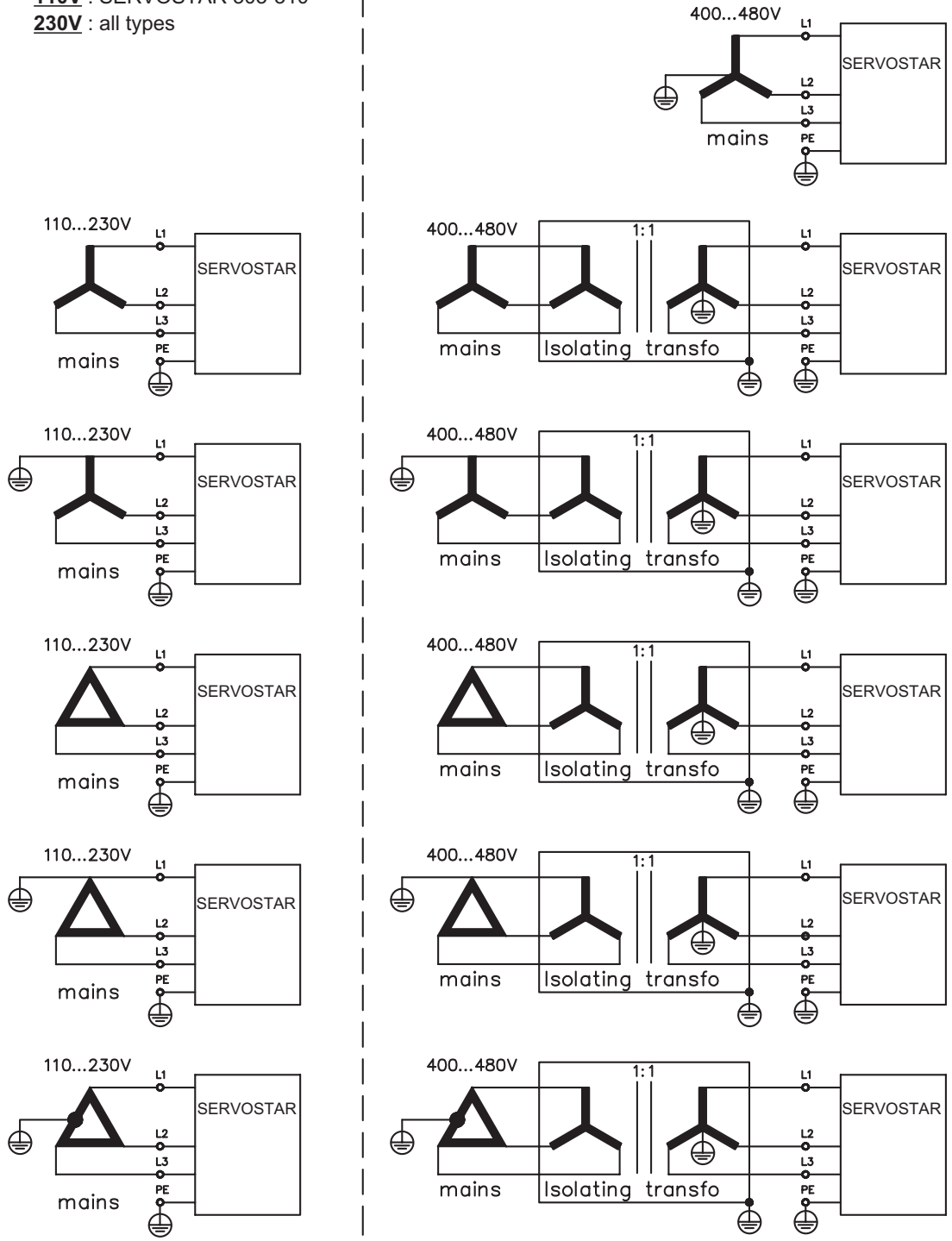

\* Order code reference see p. 125

**8.8.2 24V auxiliary supply (X4)**

- External 24V DC power supply, electrically isolated, e.g. via an isolating transformer
- Required current rating ⇒ p.21
- Integrated EMC filter for the 24V auxiliary supply

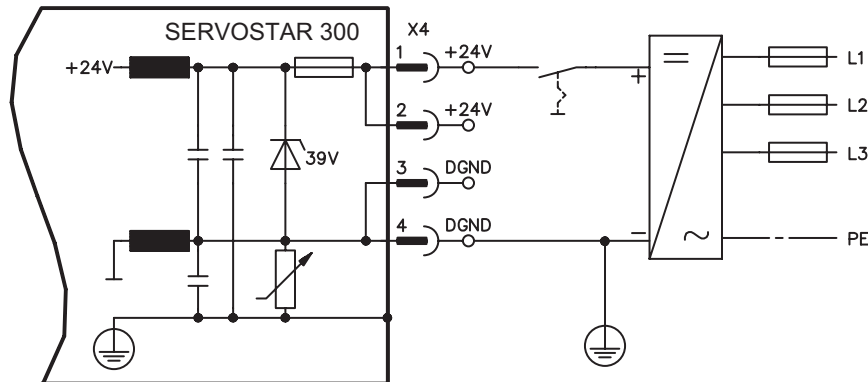

**8.8.3 Mains supply connection (X0), three phase**

- Directly to 3-phase supply network, filter is integrated
- Fusing (e.g. fusible cut-outs) to be provided by the user ⇒ p.23

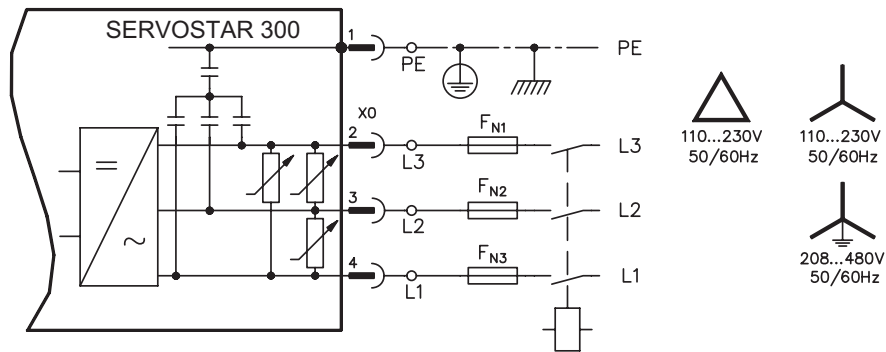

**8.8.4 Mains supply connection (X0), two phase without neutral**

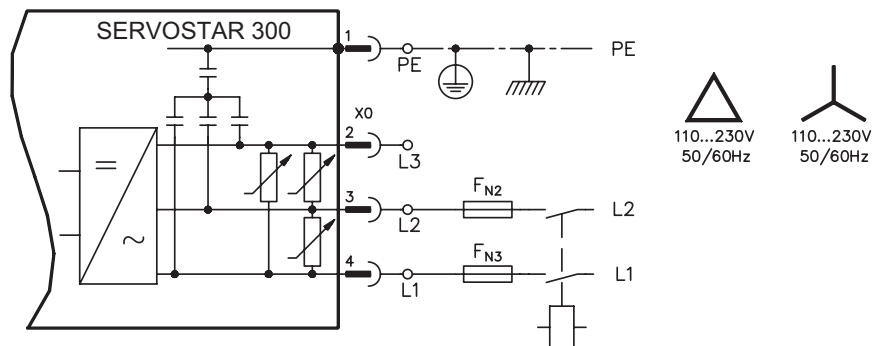

8.8.5 Mains supply connection (X0), single phase with neutral

SERVOSTAR 300 with 230V version (SERVOSTAR 303-310) can be operated with a single phase mains supply. In single phase operation the electrical power of the amplifier is limited.

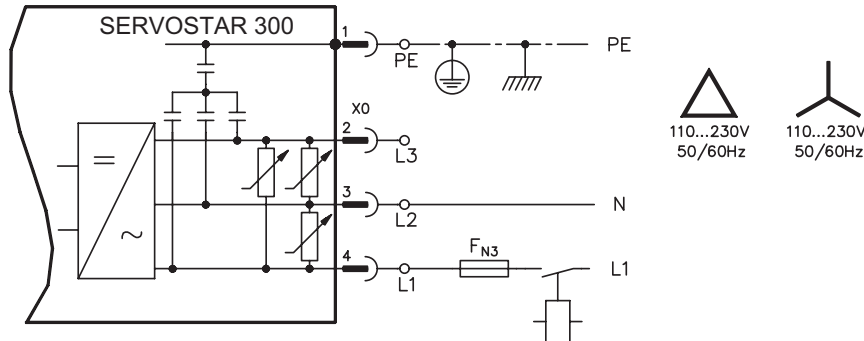

The table below shows the maximum rated power (Pn) and peak power (Pp) with single phase operation:

	SERVOSTAR 303		SERVOSTAR 306		SERVOSTAR 310	
max. electrical power	Pn / W	Pp / W	Pn / W	Pp / W	Pn / W	Pp / W
VBUSBAL0 (115V)	423	704	423	704	423	704
VBUSBAL1 (230V)	845	2535	1127	2535	1127	2535

The maximum possible current depends on the motor torque constant  $k_T$  and on the maximum speed of the connected motor:

Continuous current:  $I_{rms} = \frac{P_n \cdot 60}{2 \cdot \pi \cdot k_T \cdot n}$       peak current:  $I_{peak} = \frac{P_p \cdot 60}{2 \cdot \pi \cdot k_T \cdot n}$



Speed can be limited with the ASCII parameter VLIM to reach the necessary current for the required torque.

With a special motor type ( $k_T = \text{constant}$  depending on the motor type) the possible output current depending on speed is similar to the diagram below:

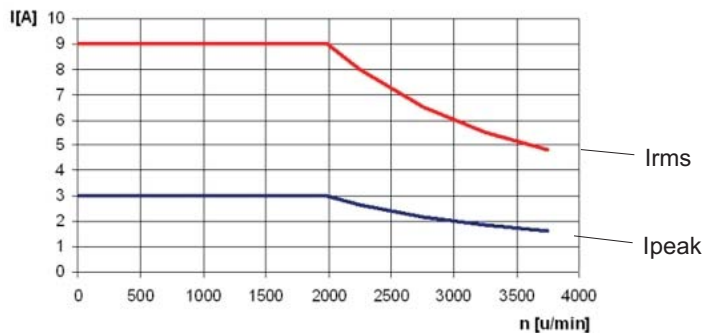

**8.9 External brake resistor (X8)**

Remove the plug-in link between the terminals X8/5 (-R<sub>B</sub>) and X8/4 (+R<sub>bint</sub>).

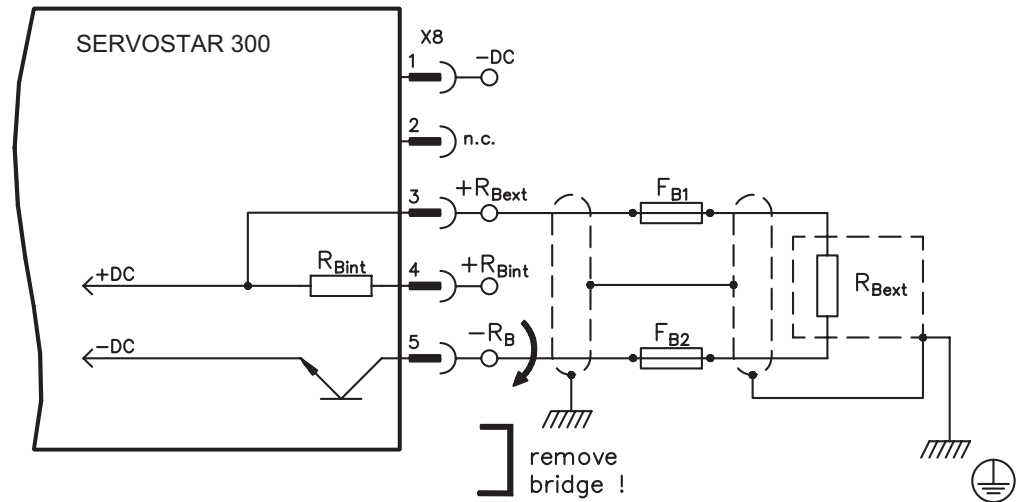

**8.10 DC bus link (X8)**

Terminals X8/1 (-DC) and X8/3 (+R<sub>Bext</sub>). Can be connected in parallel, whereby the brake power is divided between all the amplifiers that are connected to the same DC bus link circuit.

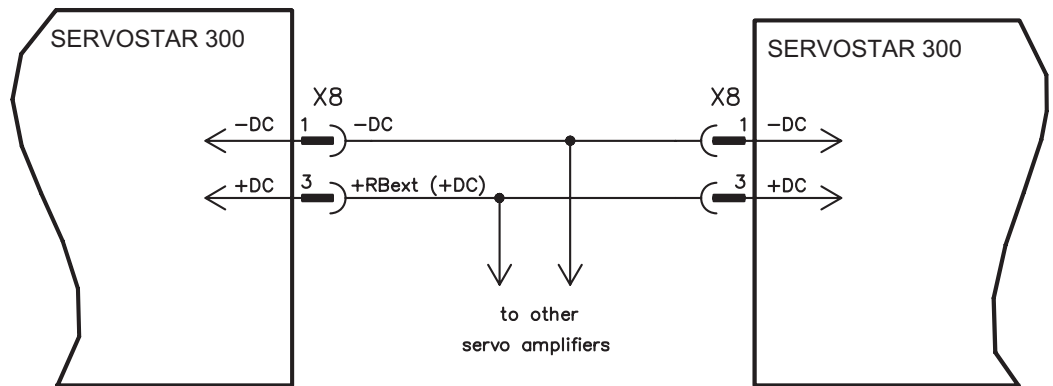

**NOTICE**

The servo amplifiers can be destroyed, if DC bus link voltages are different. Only servo amplifiers with mains supply from the same mains (identical mains supply voltage) may be connected by the DC bus link. Use unshielded single cores (2.5mm<sup>2</sup>) with a max. length of 200 mm. Use shielded cables for longer lengths.

	S700 with HWR* < 2.00	S700 with HWR* ≥ 2.00	SERVOSTAR 300
SERVOSTAR 300	no	⊗	⊗

\*HWR = Hardware Revision (see nameplate)

**SERVOSTAR 303-310**

The sum of the rated currents for all of the servo amplifiers connected in parallel to an SERVOSTAR 303-310 must not exceed 24 A.

**SERVOSTAR 341-346**

The sum of the rated currents for all of the servo amplifiers connected in parallel to an SERVOSTAR 341-346 must not exceed 40A.

Information for fusing can be found in the "Product WIKI", check [www.servostar.de](http://www.servostar.de).

### 8.11 Motor connection with brake (X9)

Together with the motor supply cable and motor winding, the power output of the servo amplifier forms an oscillating circuit. Characteristics such as cable capacity, cable length, motor inductance, frequency and voltage rise speed (see Technical Data, p. 21) determine the maximum voltage in the system.

- NOTICE** The dynamic voltage rise can lead to a reduction in the motor's operating life and, on unsuitable motors, to flashovers in the motor winding.
- Only install motors with insulation class F (acc. to IEC60085) or above
  - Only install cables that meet the requirements on p.24 and p.53.

#### Cable length ≤ 25 meters

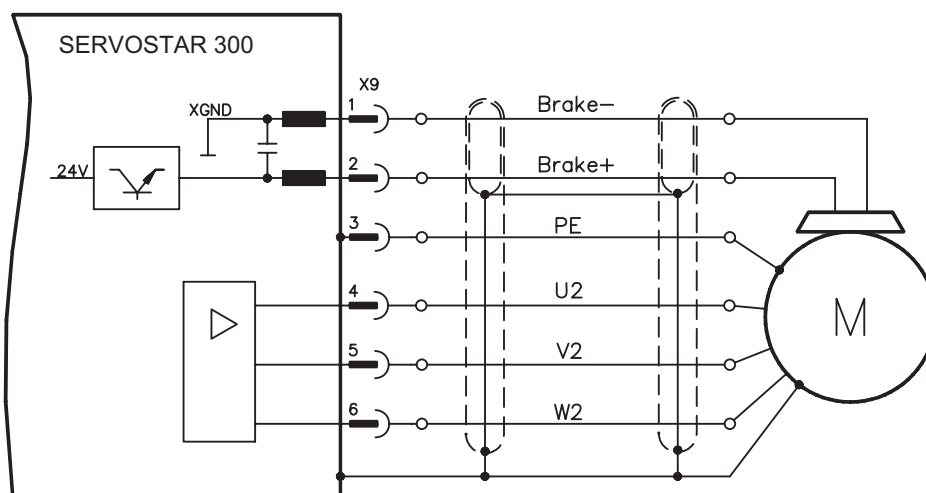

#### Cable length >25 meters

- NOTICE** With long motor cables leakage currents endanger the output stage of the servo amplifier. For cable lengths above 25m up to max. 50m, the motor choke 3YL (see accessories manual) must be wired into the motor cable, close to the amplifier.

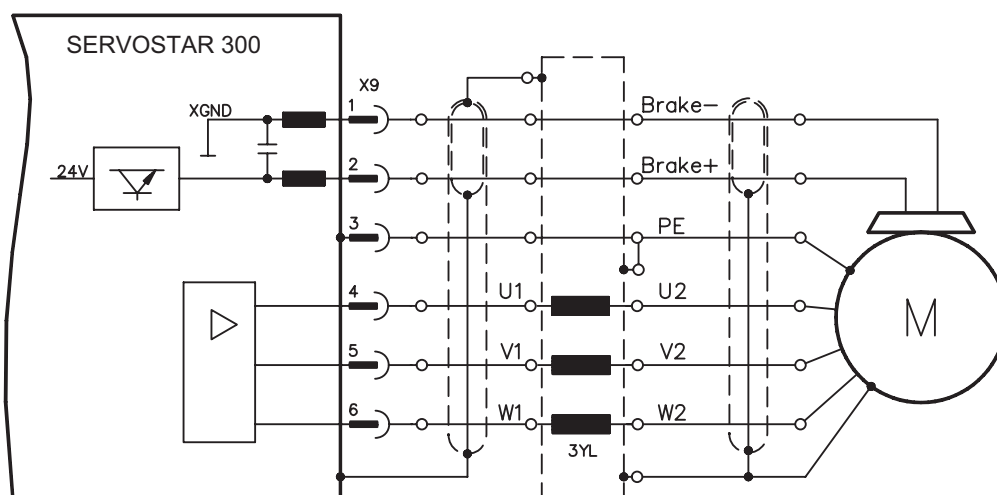

## 8.12

## Feedback

Every closed servo system will normally require at least one feedback device for sending actual values from the motor to the servo drive. Depending on the type of feedback device used, information will be fed back to the servo amplifier using digital or analog means. Up to three feedback devices can be used at the same time. SERVOSTAR 300 supports the most common types of feedback device whose functions must be assigned with the parameters

**FBTYPE** (screen page FEEDBACK), primary Feedback  
**EXTPOS** (screen page POSITION CONTROLLER), secondary Feedback  
**GEARMODE** (screen page ELECTRONIC GEARING) ⇒ p.78

in the setup software. Scaling and other settings must always be made here.

Configuration	Location	ASCII Parameter	Commu- tation	Speed control	Position- control	electr. gearing
<b>One Feedback</b>	motor	FBTYPE	X	X	X	
<b>Two Feedbacks</b> (Position externally)	motor	FBTYPE	X	X		
	externally	EXTPOS			X	
<b>Two Feedbacks</b> (Gearing externally)	motor	FBTYPE	X	X	X	
	externally	GEARMODE				X
<b>Three Feedbacks</b> (Position and Gearing externally)	motor	FBTYPE	X	X		
	externally	EXTPOS			X	
	externally	GEARMODE				X

For a detailed description of the ASCII parameters, please refer to the online help of the setup software.

The table below provides an overview of the supported feedback types, their corresponding parameters and a reference to the relevant connection diagram in each case. On each of these, the pin assignment shown on the encoder side relates to the Kollmorgen motors.

Feedback type	Connec- tor	Wiring diagram	primary	secondary
			FBTYPE	EXTPOS
Resolver	X2	⇒ p.64	0	-
SinCos Encoder BISS	X1	⇒ p.65	20, 22*, 23*, 24*	-
SinCos Encoder ENDAT	X1	⇒ p.66	4, 21*	8
SinCos Encoder HIPERFACE	X1	⇒ p.67	2	9
SinCos Encoder w/o daten channel	X1	⇒ p.68	1, 3, 7, 8	6, 7
SinCos Encoder + Hall	X1	⇒ p.69	5, 6	-
ROD** (AquadB) 5V	X1	⇒ p.70	17	-
ROD (AquadB) 5V + Hall	X1	⇒ p.71	15	-
ROD (AquadB) 5V	X5	⇒ p.72	13, 19	3
ROD (AquadB) 5V + Hall	X5/X1	⇒ p.73	18	-
ROD (AquadB) 24V	X3	⇒ p.74	16	2
ROD (AquadB) 24V + Hall	X3/X1	⇒ p.75	14	-
SSI	X5	⇒ p.76	9*	5
Hall	X1	⇒ p.77	11*	-
Sensorless (w/o Feedback)	-	-	10*	-
Step/Direction 5V	X5	⇒ p.79	-	4
Step/Direction 24V	X3	⇒ p.80	-	1

\* Can only be set on the terminal screen of the setup software

\*\* ROD is an abbreviation for "incremental encoder".

8.12.1 Resolver (X2)

Connection of a Resolver (2 to 36-poles) as a feedback system (primary, ⇨ p.63). The thermal control in the motor is connected via the resolver cable to X2 and evaluated there.

If cable lengths of more than 100m are planned, please consult our customer service.

FBTYPE: 0

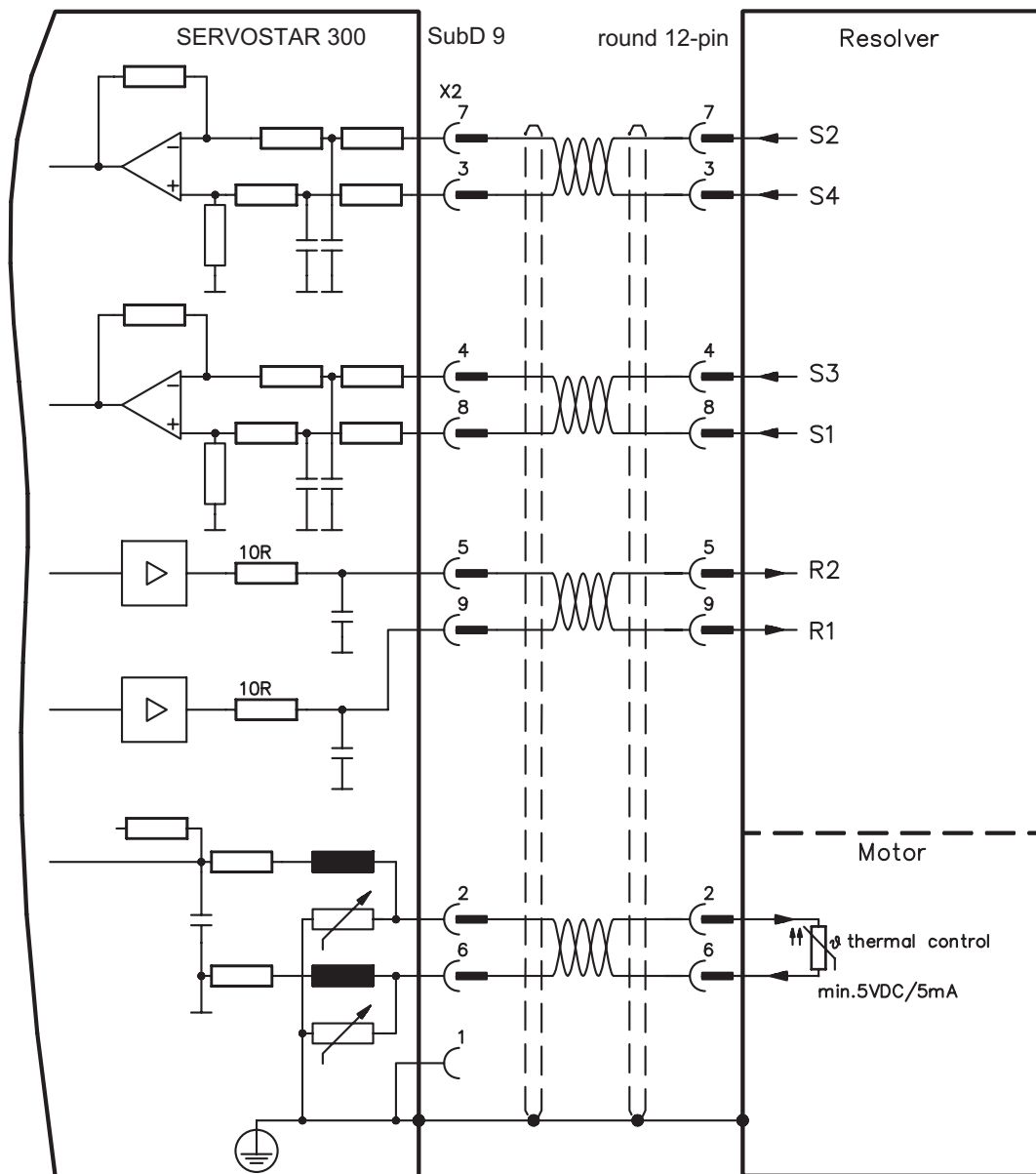

The pin assignment shown on the encoder side relates to the Kollmorgen motors.



8.12.2 Sine Encoder with BISS (X1)

Wiring of a single-turn or multi-turn sine-cosine encoder with BISS interface as a feed-back system (primary, ⇨ p.63). The thermal control in the motor is connected via the encoder cable to X1 and evaluated there.

If cable lengths of more than 50m are planned, please consult our customer service. Frequency limit (sin, cos): 350 kHz

Type	FBTYP	Up	Remarks
5V digital	20	5V +/-5%	adjust on screen page FEEDBACK
12V digital	22	7,5...11V	
5V analog	23	5V +/-5%	
12V analog	24	7,5...11V	

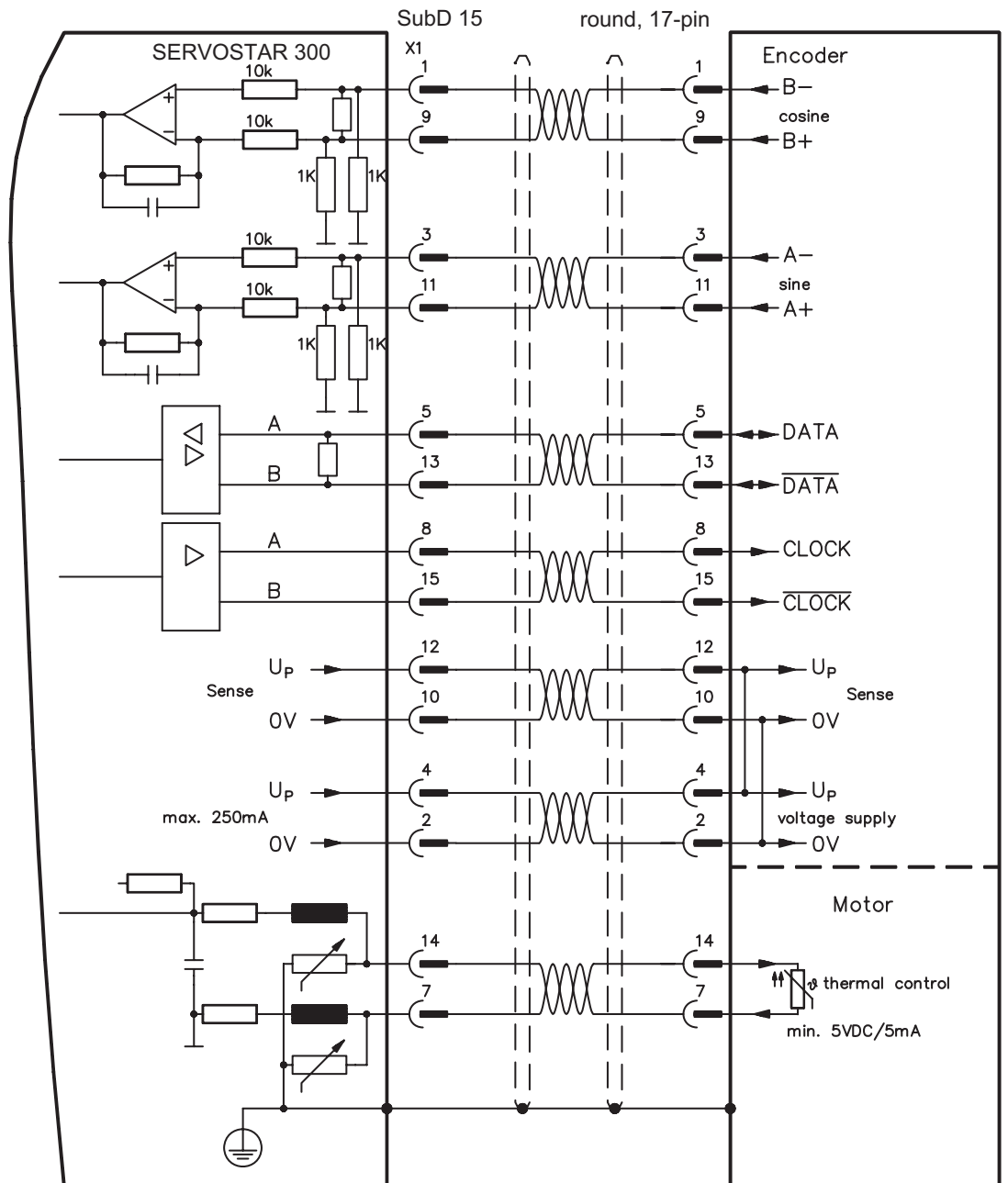

The pin assignment shown on the encoder side relates to the Kollmorgen motors.

8.12.3 Sine Encoder with EnDat 2.1

Wiring of a single-turn or multi-turn sine-cosine encoder with EnDat interface as a feedback system (primary and secondary, ⇒ p.63). Preferred types are the ECN1313 and EQN1325 encoders. The thermal control in the motor is connected via the encoder cable to X1 and evaluated there. All signals are connected using our pre-assembled encoder connection cable.

If cable lengths of more than 50m are planned, please consult our customer service.

Frequency limit (sin, cos): 350 kHz

Type	FATYPE	Remarks
ENDAT	4	adjust on screen page FEEDBACK
ENDAT + Wake&Shake	21	adjust on screen page TERMINAL

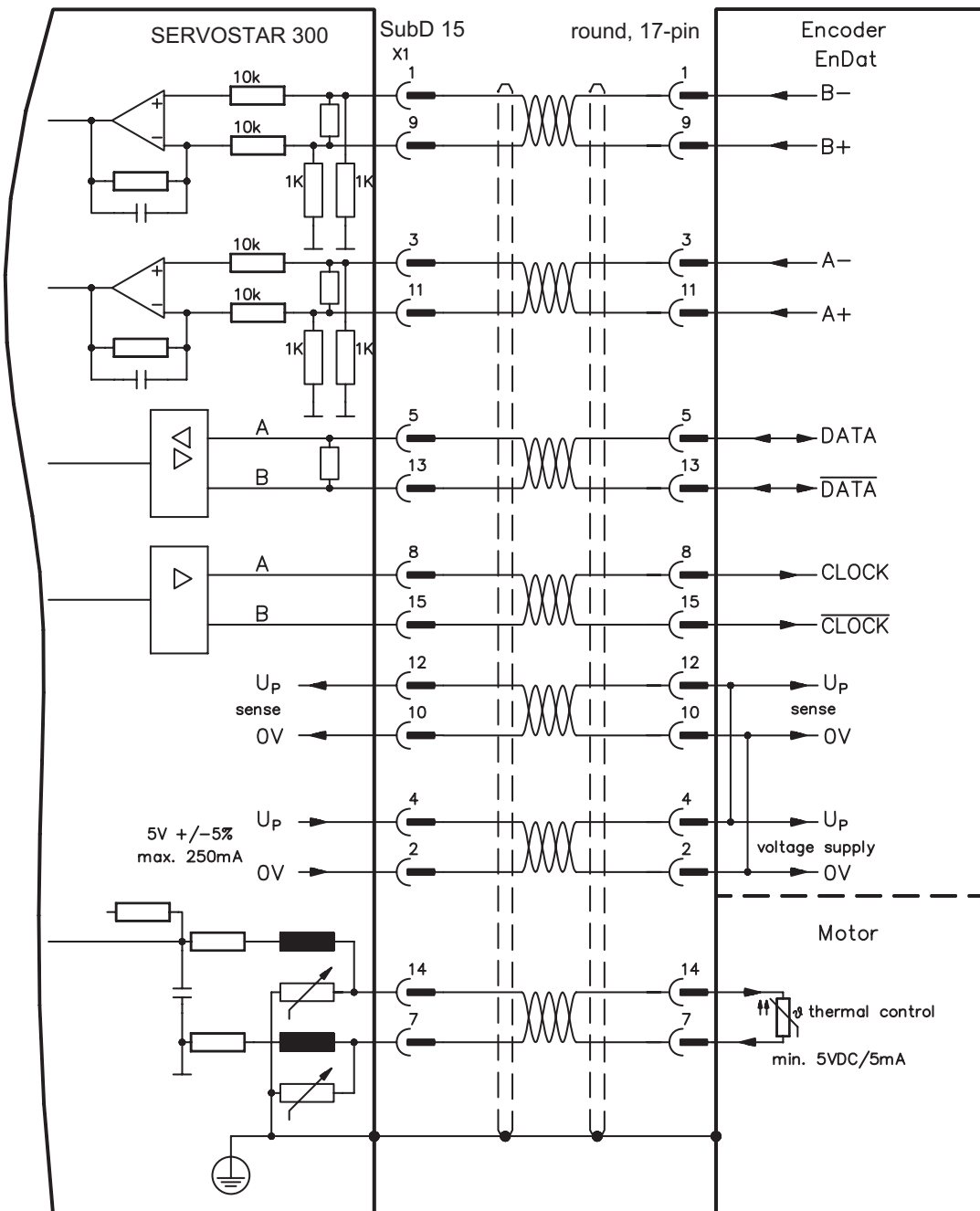

The pin assignment shown on the encoder side relates to the Kollmorgen motors.

8.12.4 Sine Encoder with HIPERFACE (X1)

Wiring of a single-turn or multi-turn sine-cosine encoder with HIPERFACE interface as a feedback system (primary and secondary, ⇒ p.63).

The thermal control in the motor is connected via the encoder cable to X1 and evaluated there. All signals are connected using our pre-assembled encoder connection cable.

If cable lengths of more than 50m are planned, please consult our customer service.

Frequency limit (sin, cos): 350 kHz, FBTYPE: 2

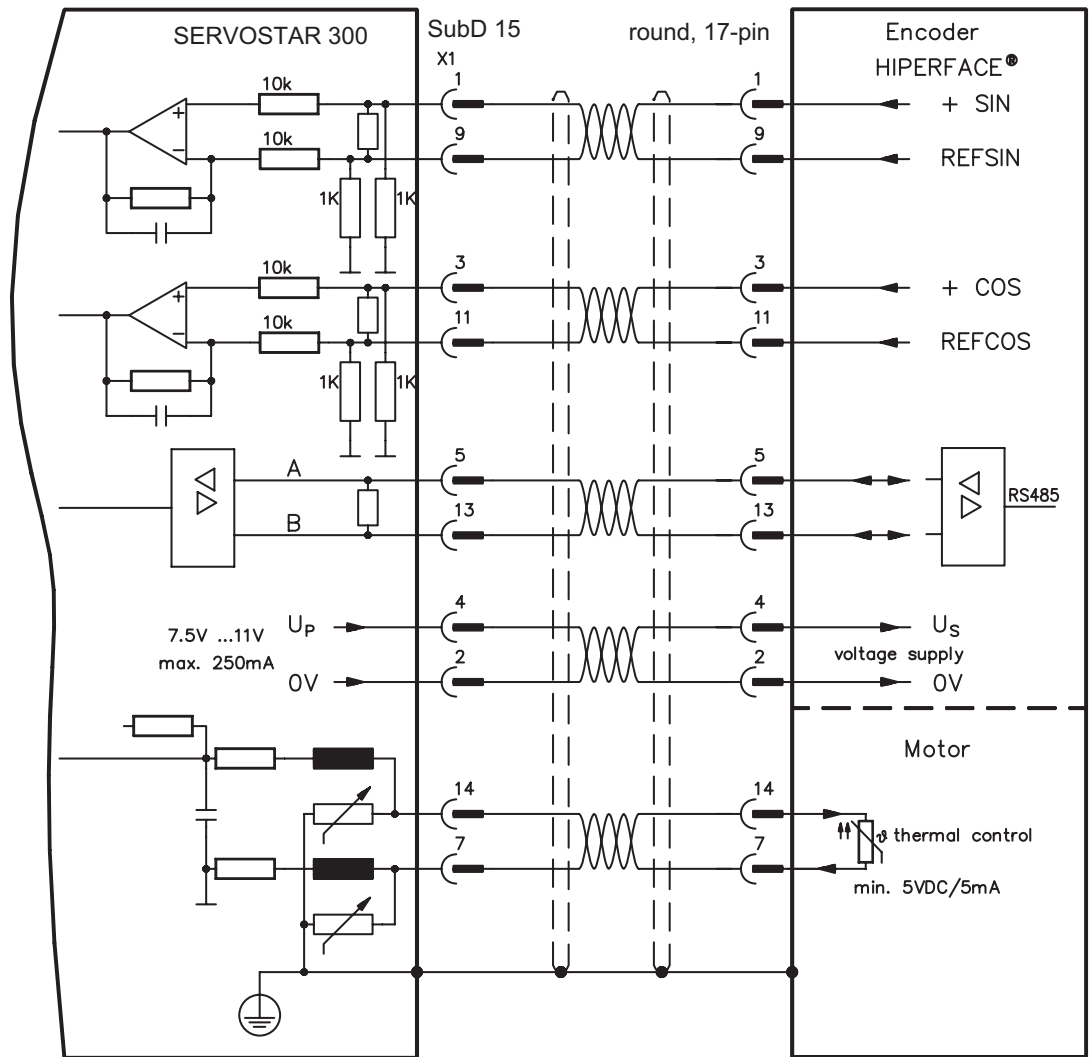

The pin assignment shown on the encoder side relates to the Kollmorgen motors.

8.12.5 Sine Encoder without data channel (X1)

Wiring of a sine-cosine encoder without data channel as a feedback (primary and secondary, ⇒ p.63). The thermal control in the motor is connected via the encoder cable to X1 and evaluated there. Every time the 24V auxiliary voltage is switched on, the amplifier needs start-up information for the position controller (parameter value MPHASE). Depending on the feedback type either wake&shake is executed or the value for MPHASE is read out of the amplifier's EEPROM.

**⚠ WARNING** With vertical load the load could fall during wake&shake, because the brake is not active and torque is not sufficient to hold the load. Don't use this feedback type with vertical load (hanging load).

If lead lengths of more than 50m are planned, please consult our customer service.  
 Frequency limit (sin, cos): 350 kHz

Type	FBTYP	Up	Remarks
SinCos 5V	1	5V +/-5%	MPHASE from EEPROM
SinCos 12V	3	7,5...11V	MPHASE from EEPROM
SinCos 5V	7	5V +/-5%	MPHASE with wake & shake
SinCos 12V	8	7,5...11V	MPHASE with wake & shake

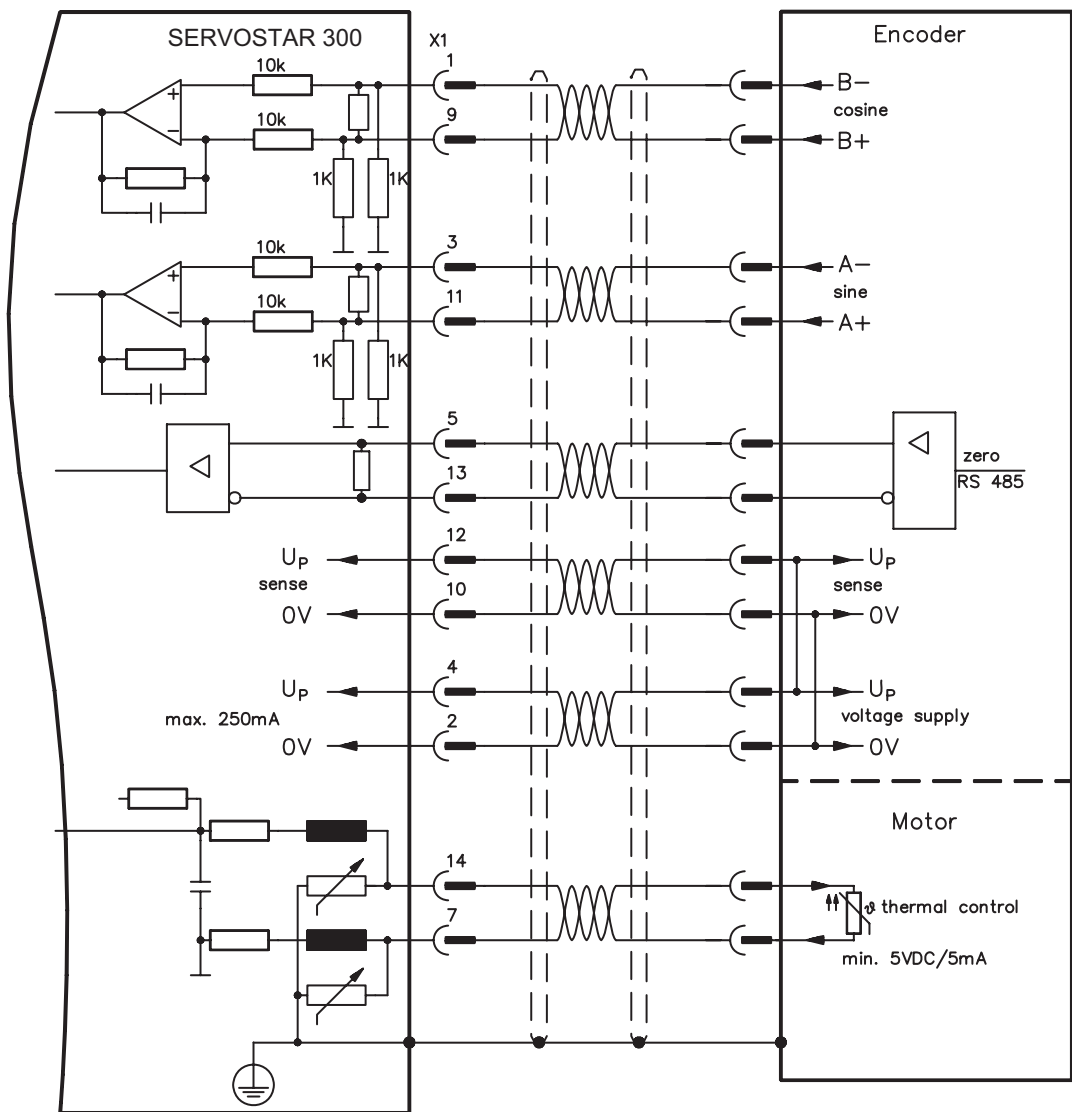

8.12.6 Sine Encoder with Hall (X1)

Feedback devices (incremental or sine-cosine), which don't deliver an absolute information for commutation, can be used as complete feedback system combined with an additional Hall encoder (primary, ⇒ p.63).

All signals are connected to X1 and evaluated there. If cable lengths of more than 25m are planned, please consult our customer service.

Frequency limit (sin, cos): 350 kHz

Type	FBTYPE	Up	Remarks
SinCos 5V with Hall	5	5V +/-5%	
SinCos 12V with Hall	6	7,5...11V	

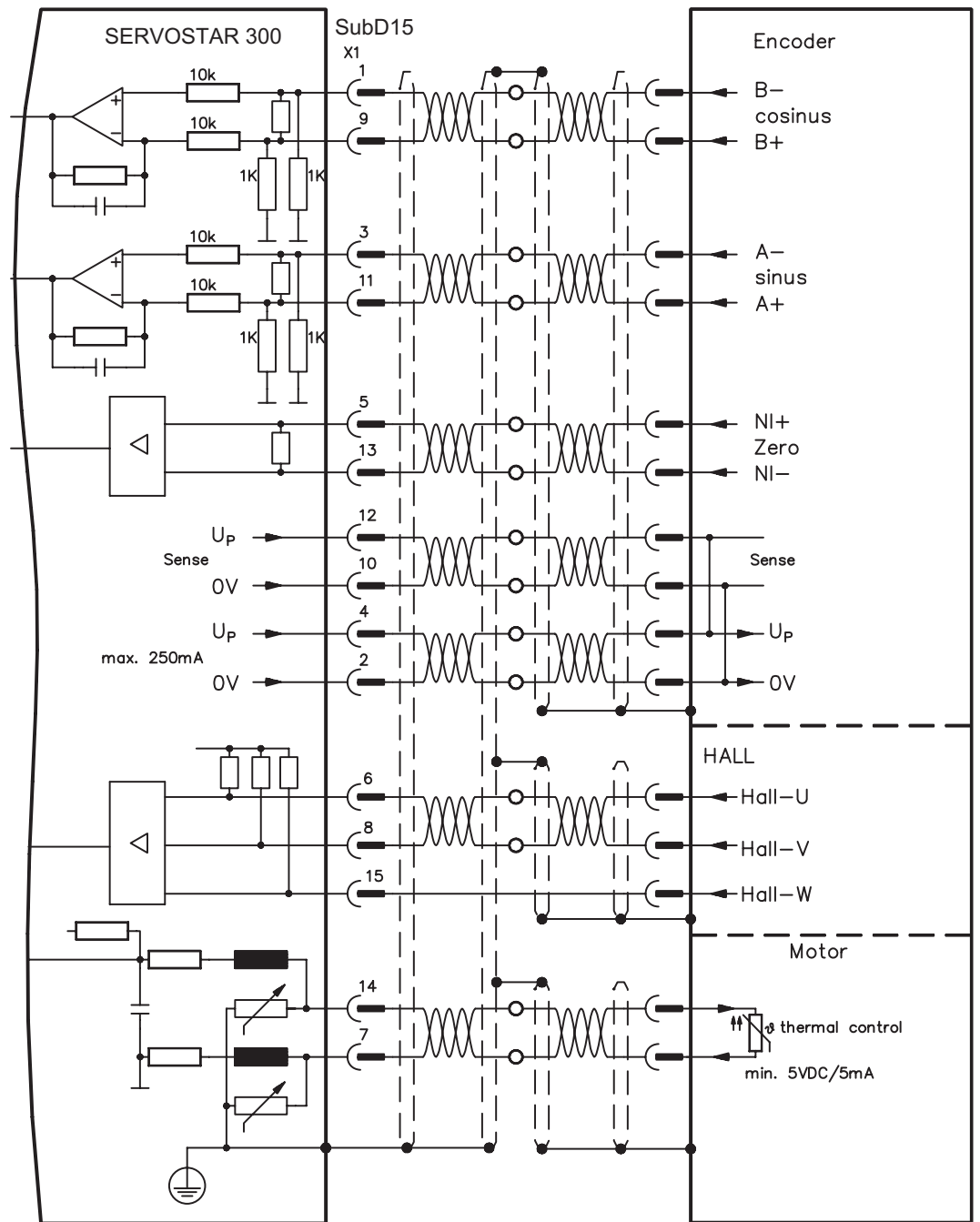

8.12.7 ROD (AquadB) 5V (X1)

Wiring of a 5V incremental encoder (ROD, AquadB) as a feedback (primary, ⇨ p.63). The thermal control in the motor is connected to X1 and evaluated there. Every time the 24V auxiliary voltage is switched on, the amplifier need start-up information for the position controller (parameter value MPHASE). With this feedback type the amplifier executes a wake&shake every time the 24V auxiliary voltage is switched on

**⚠ WARNING** With vertical load the load could fall during wake&shake, because the brake is not active and torque is not sufficient to hold the load. Don't use this feedback type with vertical load (hanging load)..

If lead lengths of more than 50m are planned, please consult our customer service.

Frequency limit (A, B): 350 kHz, FBTYPE: 17

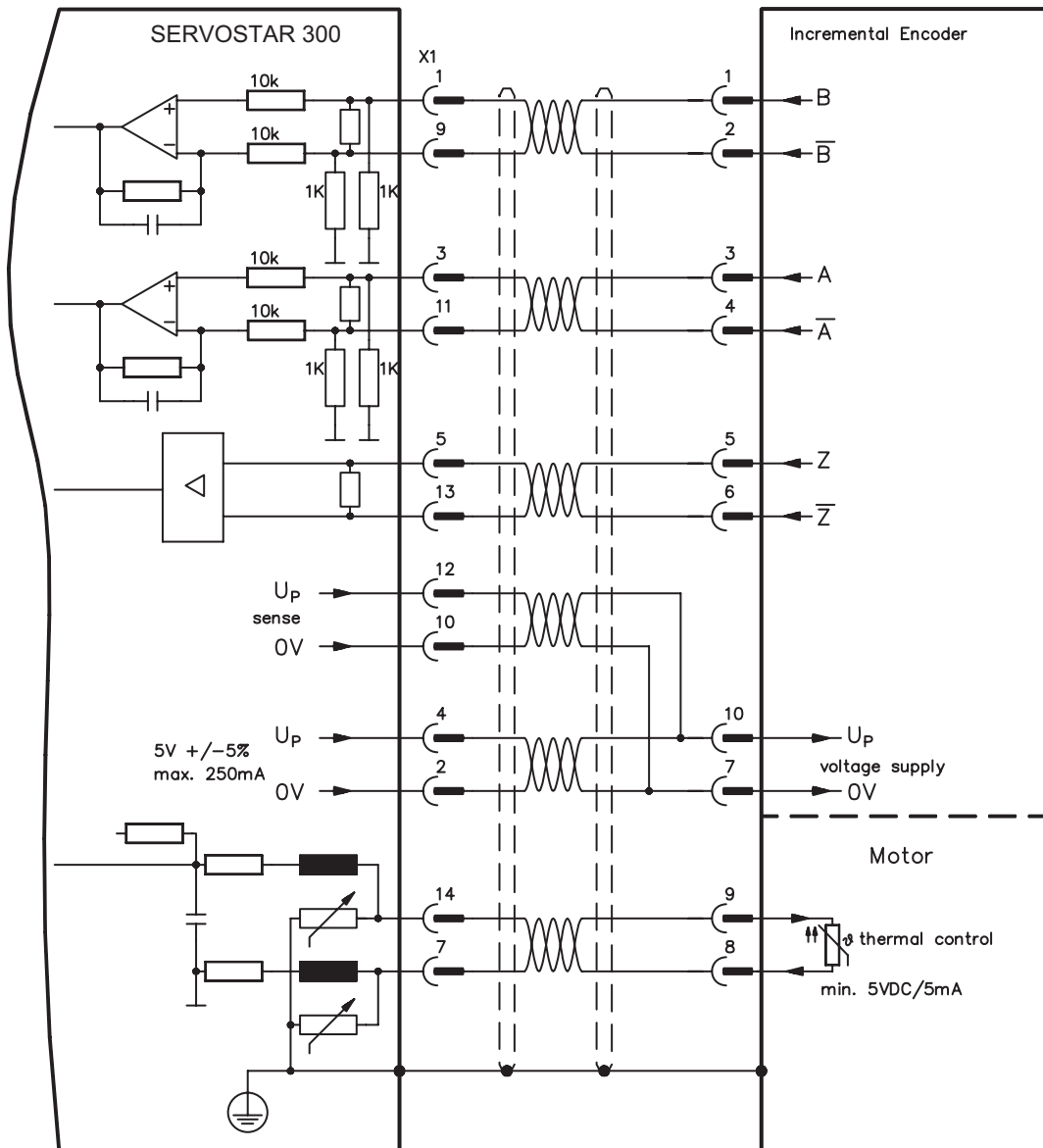

The pin assignment shown on the encoder side relates to the Kollmorgen motors.

8.12.8 ROD (AquadB) 5V with Hall (X1)

Wiring of a ComCoder as a feedback unit (primary, ⇒ p.63). For the commutation hall sensors are used and for the resolution an incremental encoder. The thermal control in the motor is connected to X1 and evaluated there. With our ComCoder cable all signals are connected correctly. With separate feedback devices (Encoder and Hall are two devices) the wiring must be done similar to chapter 8.12.6, but the amplifier's pinout is identical to the wiring diagram shown below.

If cable lengths of more than 25m are planned, please consult our customer service.

Frequency limit (A,B): 350 kHz, FBTYPE: 15

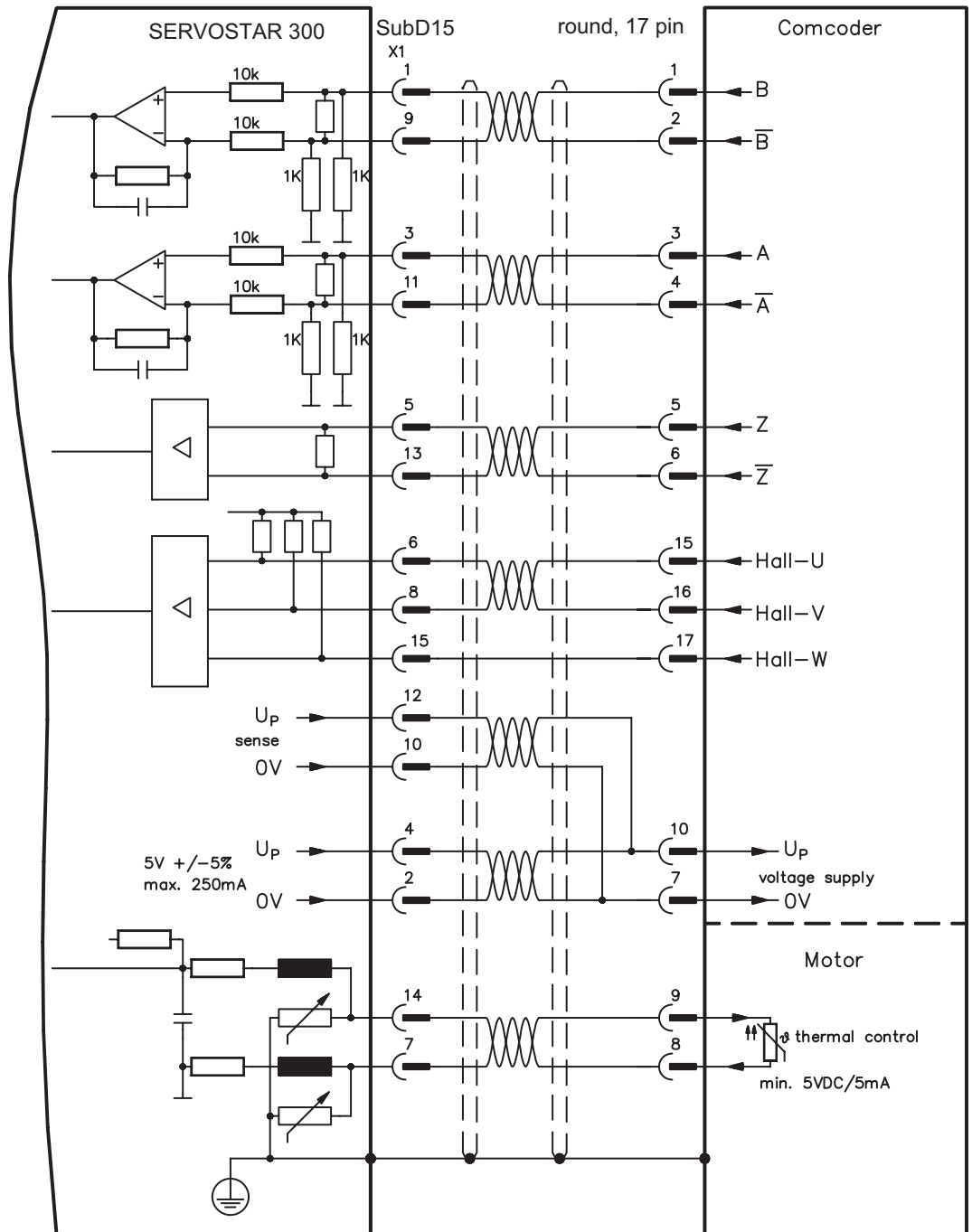

The pin assignment shown on the encoder side relates to the Kollmorgen motors.

8.12.9 ROD (AquadB) 5V (X5)

A 5V incremental encoder (AquadB) can be used as standard motor feedback (primary and secondary, ⇒ p.63). The thermal control in the motor is connected to X1. Every time the 24V auxiliary voltage is switched on, the amplifier need start-up information for the position controller (parameter value MPHASE). Depending on the feedback type either wake&shake is executed or the value for MPHASE is read out of the amplifier's EEPROM.

**⚠ WARNING** With vertical load the load could fall during wake&shake, because the brake is not active and torque is not sufficient to hold the load. Don't use this feedback type with vertical load (hanging load).

If lead lengths of more than 50m are planned please consult our customer service.

Frequency limit (A, B, N): 1.5 MHz

Type	FBTYPE	Up	Remarks
ROD (AquadB) 5V	13	5V +/-5%	MPHASE from EEPROM
ROD (AquadB) 5V	19	5V +/-5%	MPHASE from wake & shake

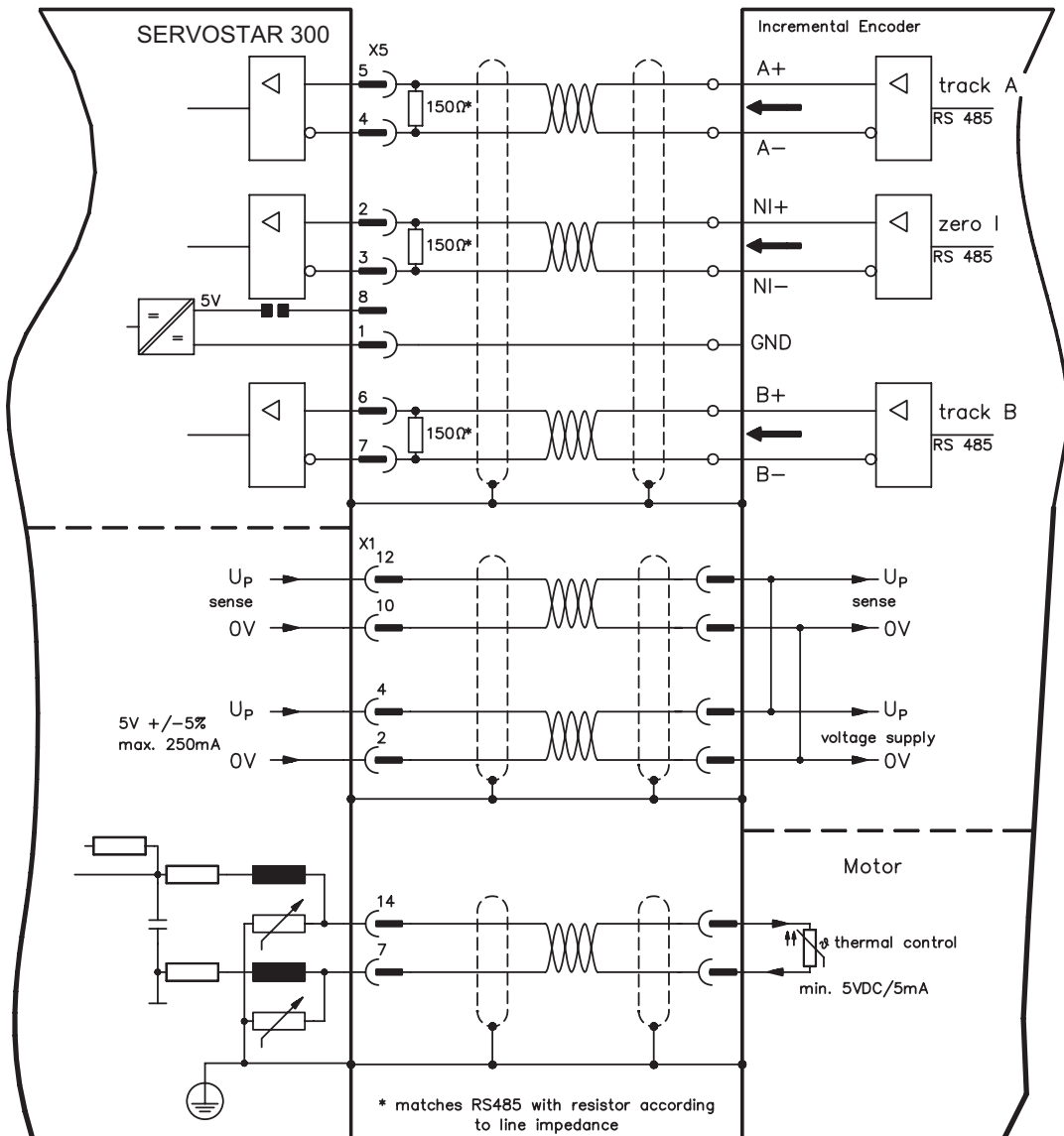



8.12.10 ROD (AquadB) 5V with Hall (X5/X1)

Wiring of a 5V incremental encoder (ROD, AquadB) with Hall sensors as a feedback unit (primary, ⇒ p.63). For the commutation hall sensors are used and for the resolution an incremental encoder. The thermal control in the motor is connected to X1 and evaluated there.

If cable lengths of more than 25m are planned, please consult our customer service.

Frequency limit X5: 1.5 MHz, X1: 350 kHz, FBTYPE: 18

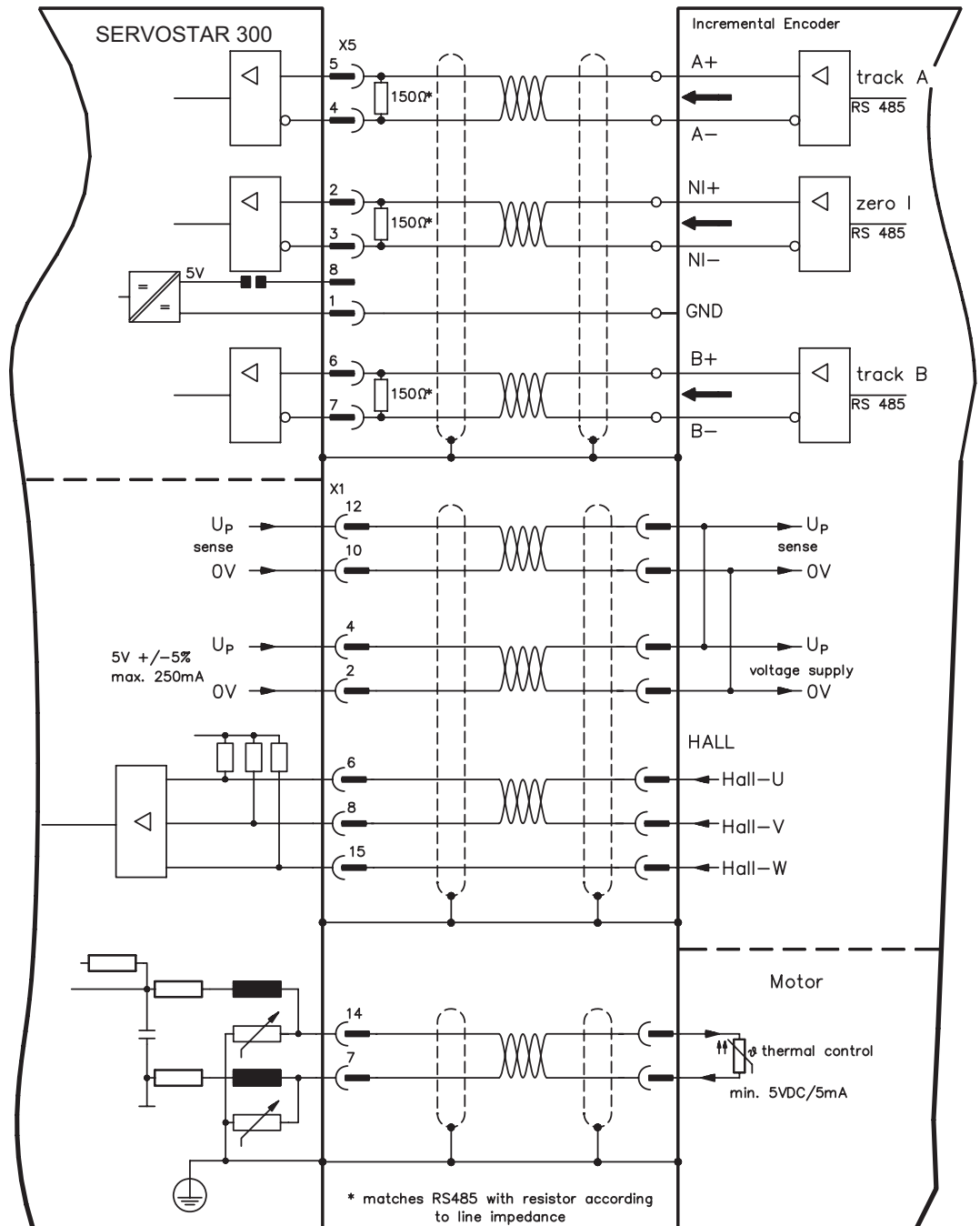

8.12.11 ROD (AquadB) 24V (X3)

Wiring of a 24V incremental encoder (ROD AquadB) as a feedback system (primary or secondary, ⇒ p.63). The thermal control in the motor is connected to X1 or X2. Every time the 24V auxiliary voltage is switched on, the amplifier need start-up information for the position controller (parameter value MPHASE). With this feedback type the amplifier executes a wake&shake is executed every time the 24V auxiliary voltage is switched on.

**⚠ WARNING** With vertical load the load could fall during wake&shake, because the brake is not active and torque is not sufficient to hold the load. Don't use this feedback type with vertical load (hanging load).

This uses the digital inputs DIGITAL-IN 1 and 2 on connector X3.

If cable lengths of more than 25m are planned, please consult our customer service.

Frequency limit: 100 kHz, transition time  $t_v \leq 0,1\mu s$ , FBTYPE: 16

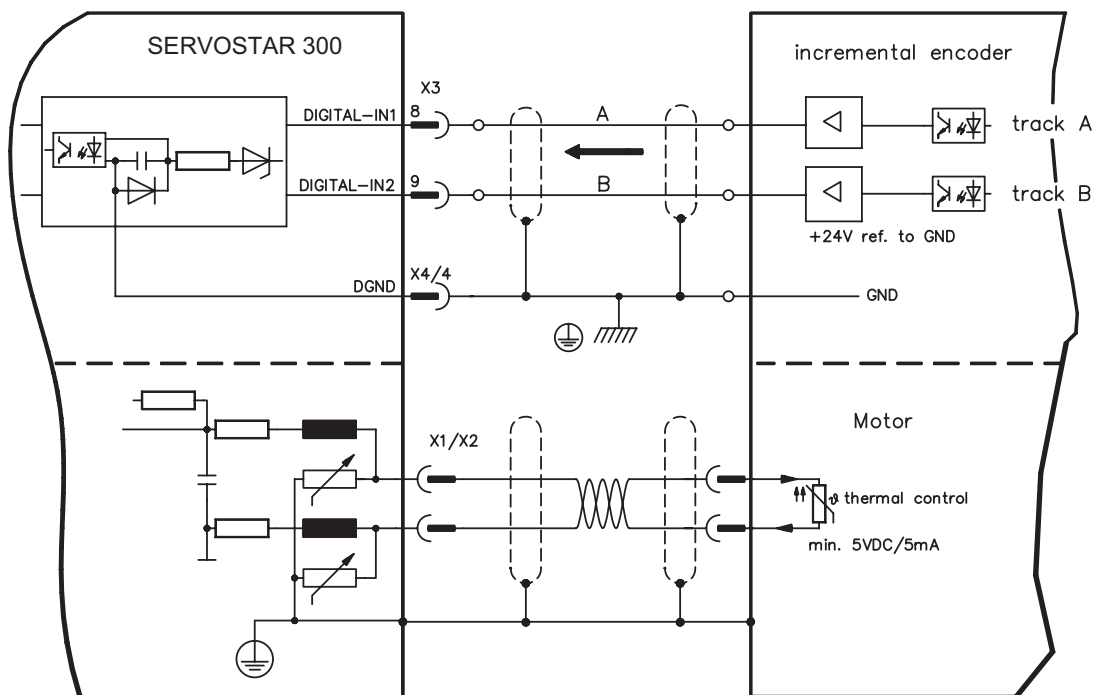

8.12.12 ROD (AquadB) 24V with Hall (X3/X1)

Wiring of a 24V incremental encoder (ROD, AquadB) and Hall sensors as a feedback unit (primary, ⇒ p.63). For the commutation hall sensors are used and for the resolution an incremental encoder. The thermal control in the motor is connected to X1 and evaluated there.

If cable lengths of more than 25m are planned, please consult our customer service.

Frequency limit X3: 100 kHz, X1: 350 kHz FBTYP: 14

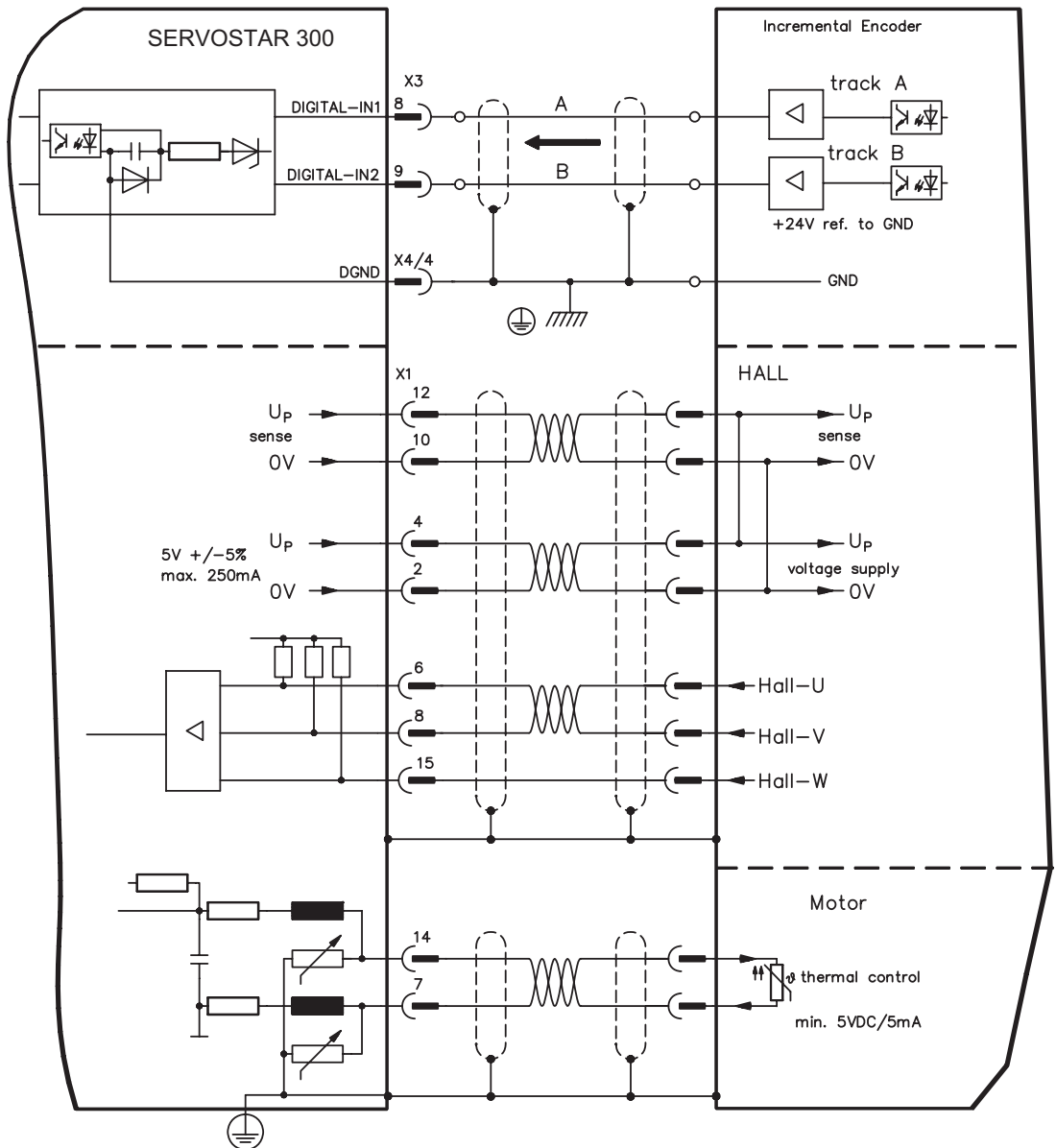

8.12.13 SSI Encoder (X5)

Wiring of a synchronous serial absolute-encoder as a feedback system (primary or secondary, ⇒ p.63). The signal sequence can be read in **Gray** code or in **Binary** (standard) code.

The thermal control in the motor is connected to X1 and evaluated there.

If cable lengths of more than 50m are planned, please consult our customer service.

Frequency limit: 1.5 MHz, FBTYPE: 9 (adjustable with Terminal)

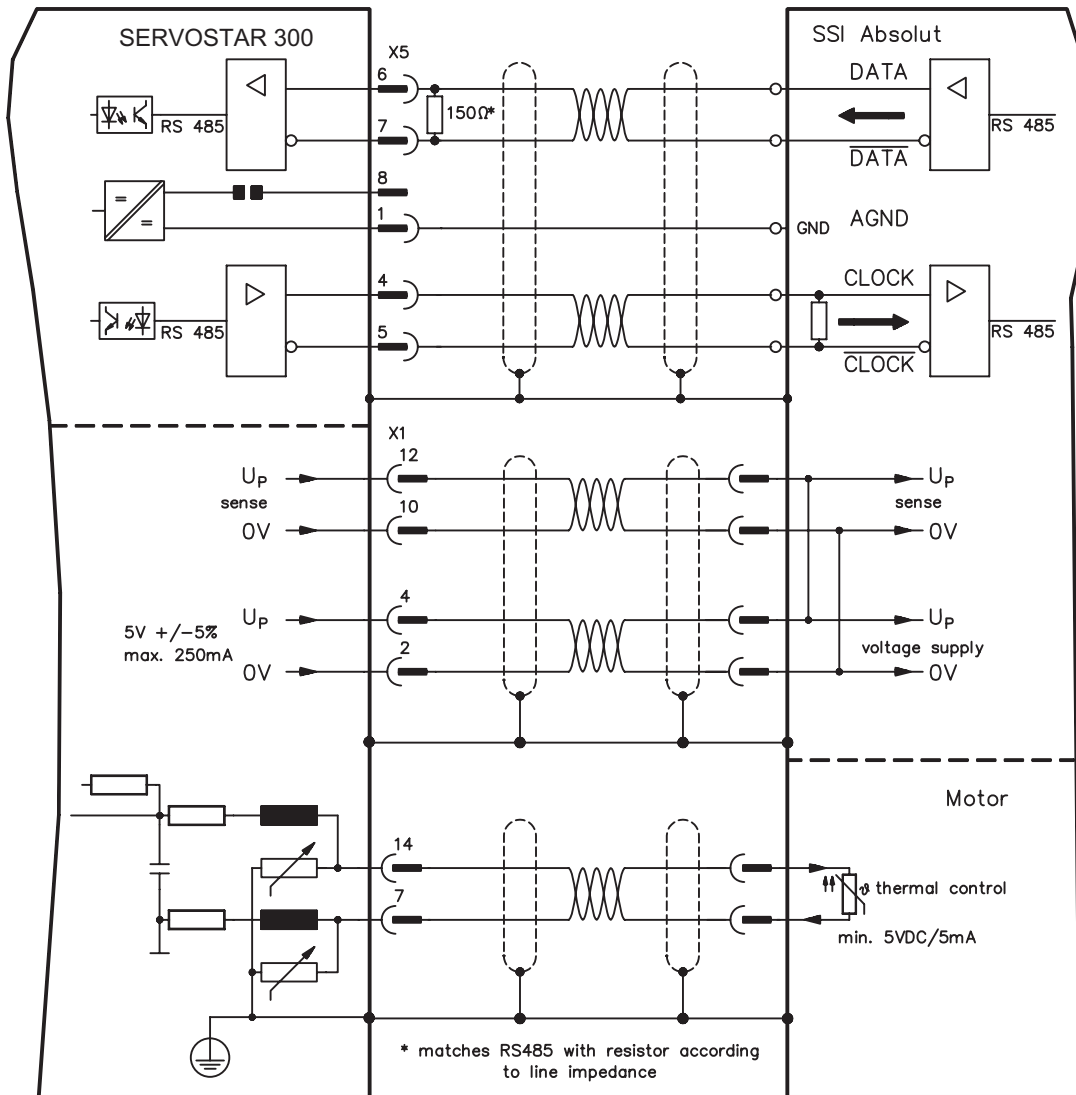

8.12.14 Hall sensors (X1)

Wiring of Hall sensors as a feedback unit (primary or secondary, ⇨ p.63).

The thermal control in the motor is connected to X1 and evaluated there.

If cable lengths of more than 25m are planned, please consult our customer service.

Frequency limit: 350 kHz, FBTYPE: 11 (adjustable with Terminal)

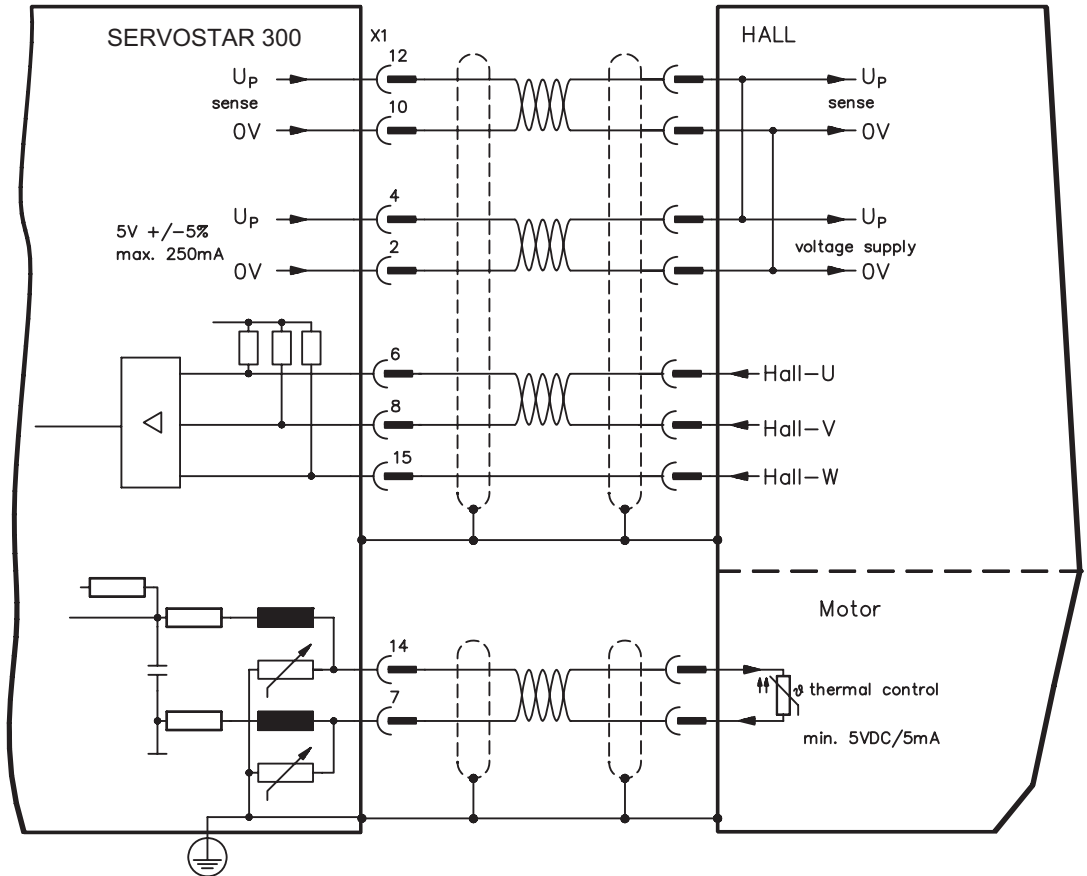

### 8.13 Electronic Gearing, Master-slave operation

In the case of the “electronic gearing” functionality (see setup software and description of GEARMODE parameter), the servo amplifier is controlled by a secondary feedback device as a slave.

It is possible to set up master/slave systems, use an external encoder as a setpoint encoder or connect the amplifier to a stepper motor control.

The amplifier is parameterized using the setup software (electronic gearing). The resolution (number of pulses per revolution) can be adjusted.

The following types of external encoder can be used:

secondary Feedback type	Connector	Wiring diagram	GEARMODE
SinCos Encoder ENDAT	X1	⇒ p.66	8
SinCos Encoder HIPERFACE	X1	⇒ p.67	9
SinCos Encoder w/o data channel	X1	⇒ p.68	6, 7
ROD* (AquadB) 5V	X5	⇒ p.72	3
ROD (AquadB) 24V	X3	⇒ p.74	2
SSI	X5	⇒ p.76	5
Step/direction 5V	X5	⇒ p.79	4
Step/direction 24V	X3	⇒ p.80	1

\* ROD is an abbreviation for incremental encoder

#### 8.13.1 Connection to an incremental encoder (AquadB) master, 5 V (X5)

Wiring of the servo amplifier (SubD connector X5) to an incremental encoder with a 5 V signal level.

You can, for example, link several SERVOSTAR amplifiers together in master-slave operation.

Master: position output to X5 (screen page "Encoder emulation")

Slave: screen page "Electronic gearing" (GEARMODE)

Up to 16 slave amplifiers can be controlled by the master, via the encoder output.

Frequency limit: 1.5 MHz

Example for Master-Slave operation with two SERVOSTAR amplifiers:

Slave **GEARMODE: 3**

Master **ENCMODE:1**

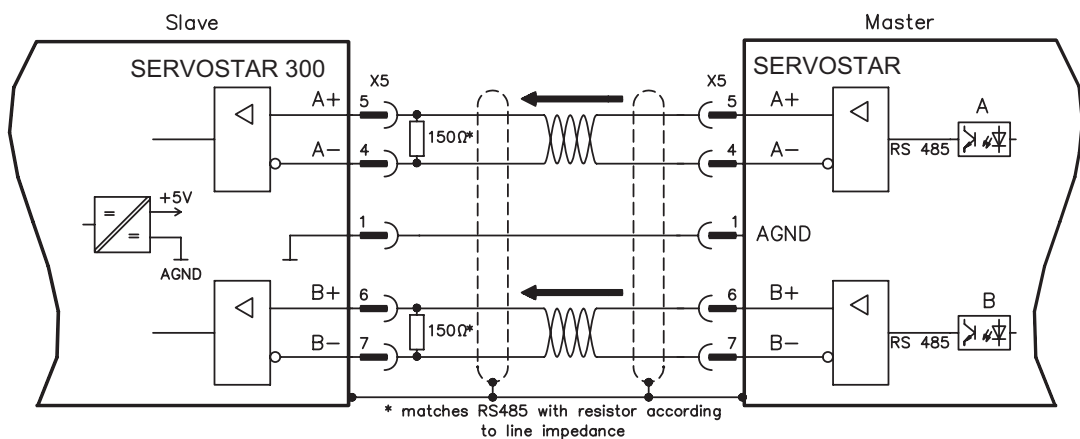

### 8.13.2 Connection to stepper motor controllers (step and direction)

You can connect the servo amplifier to a third-party stepper-motor controller. Parameter setting for the slave amplifier is carried out with the aid of the setup software (electronic gearing). The number of steps can be adjusted, so that the servo amplifier can be adapted to match the step-direction signals of any stepper controller. Various monitoring signals can be generated.



**Observe the frequency limit!**

**Using an A quad B encoder provides better EMC noise immunity.**

#### Speed profile and signal diagram

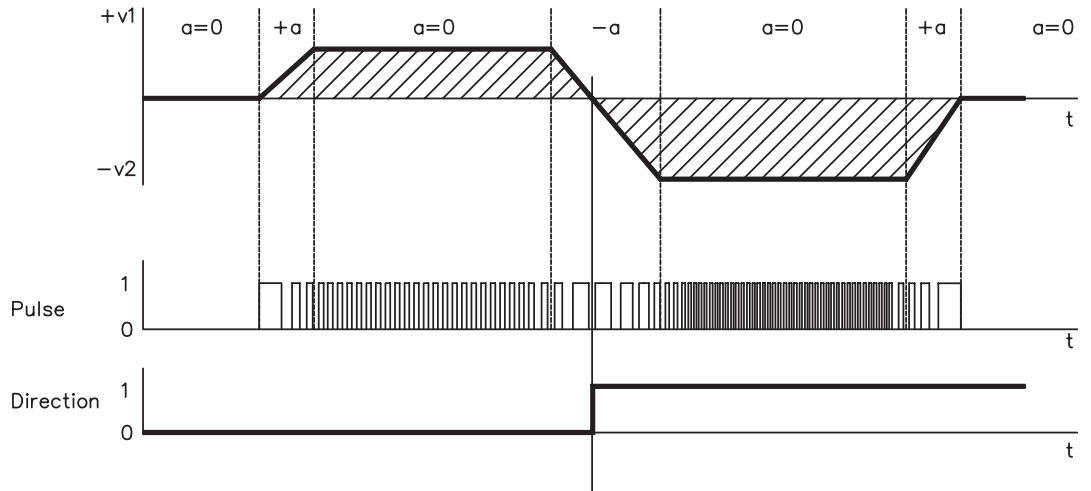

#### Equivalences

- path traversed  $s$  ——— number of pulses
- velocity  $v$  ——— pulse frequency
- acceleration  $a$  ——— rate of change of pulse frequency

#### 8.13.2.1 Step/Direction with 5 V signal level (X5)

Wiring of the servo amplifier (SubD connector X5) to a stepper-motor controller with a 5 V signal level.

Frequency limit: 1.5 MHz, GEARMODE: 4

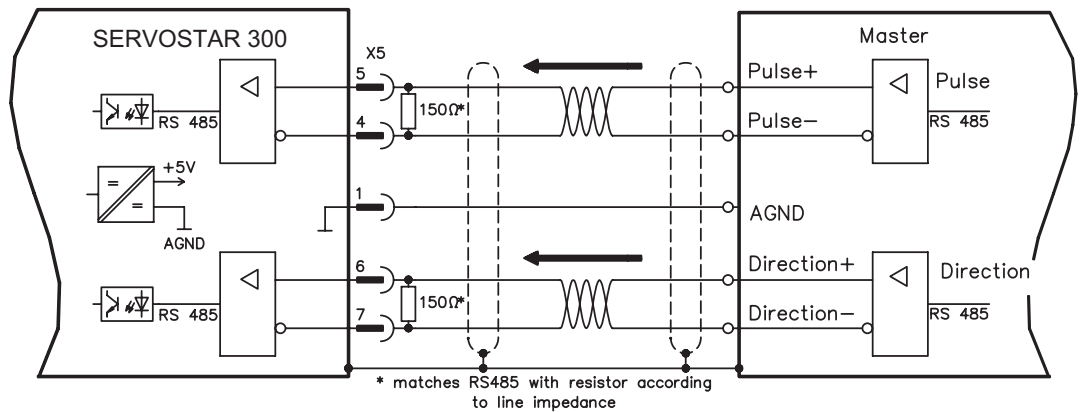

8.13.2.2 Step/Direction with 24 V signal level (X3)

Wiring of the servo amplifier to a stepper-motor controller with a 24 V signal level. Used are the digital inputs DIGITAL-IN 1 and 2 on connector X3.

Frequency limit: 100 kHz, GEARMODE: 1

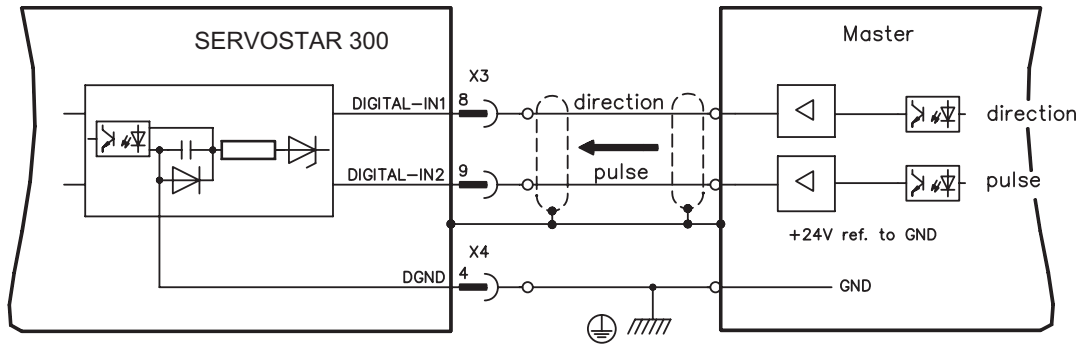



8.14 Encoder emulation

8.14.1 Incremental encoder output - A quad B (X5)

The incremental-encoder interface is part of the standard package. Select encoder function ROD (A Quad B) Encoder (“Encoder Emulation” screen page). The servo amplifier calculates the motor shaft position from the cyclic- absolute signals of the resolver or encoder, generating incremental-encoder compatible pulses from this information. Pulse outputs on the SubD connector X5 are 2 signals, A and B, with 90° phase difference (i.e. in quadrature, hence the alternative term “A quad B” output), with a zero pulse. The resolution (before multiplication) can be set by the RESOLUTION function:

Enc. function (ENCMODE)	Feedback system	Resolution (lines)	Zero pulse (NI)
ROD (1)	2 pole Resolver	256...4096	once per turn (only at A=B=1)
	Encoder	256...524288 (2 <sup>8</sup> ... 2 <sup>19</sup> )	once per turn (only at A=B=1)
ROD interpolation (3)	Encoder	2 <sup>2</sup> ... 2 <sup>7</sup> (multiplication) TTL line x encoder resolution	encoder signal passed through from X1 to X5

Use the NI-OFFSET parameter to adjust + save the zero pulse position within one mechanical turn. The drivers operate off an internal supply voltage.



The maximum permissible cable length is 100 meters.

Connections and signals for the incremental encoder interface :

Default count direction: UP when the motor shaft is rotating clockwise (looking at the shaft's end)

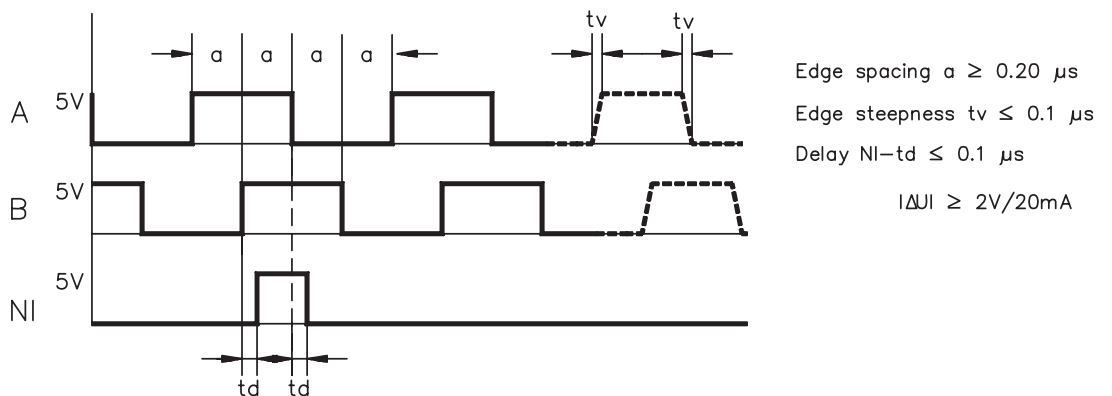
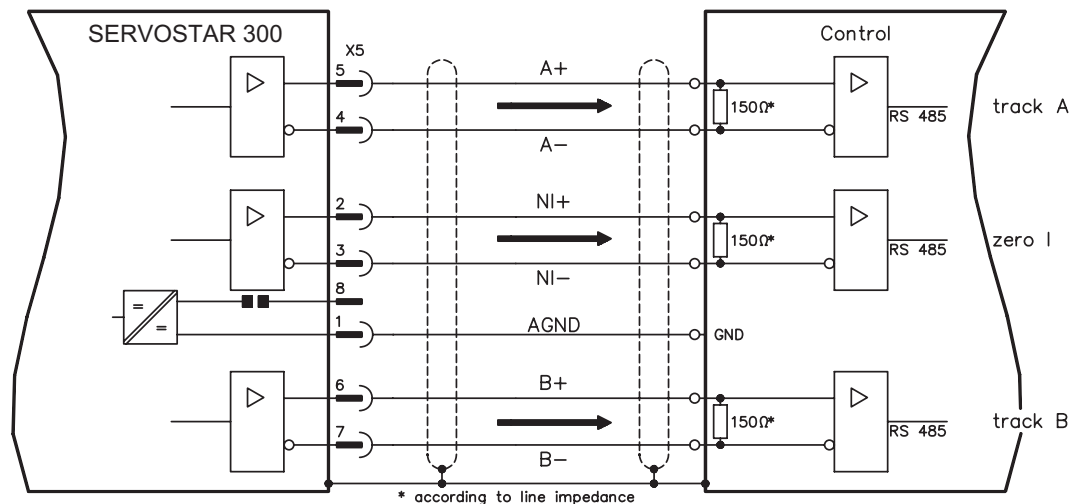

8.14.2 SSI encoder output (X5)

The SSI interface (synchronous serial absolute-encoder emulation) is part of the standard package. Select encoder function SSI (“Encoder Emulation” screen page). The servo amplifier calculates the motor shaft position from the cyclic-absolute signals of the resolver or encoder. From this information a SSI date (Stegmann patent specification DE 3445617C2) is provided. Max 32 bits are transferred. The leading data bit contains the number of revolutions and are selectable from 12 to 16 bits. The following max. 16 bits contain the resolution and are not variable.

The following table shows the allocation of the SSI date depending upon selected number of revolutions:

		Revolution																Resolution (variable)															
		SSIREVOL																															
Bit	15	14	13	12	11	10	9	8	7	6	5	4	3	2	1	0	15	14	13	12	11	10	9	8	7	6	5	4	3	2	1	0	
	14																																
	13																																
	12																																
	11																																

The signal sequence can be output in **Gray** code or in **Binary** (standard) code. The servo amplifier can be adjusted to the clock frequency of your SSI-evaluation with the setup software (cycle time 1,3 μs or 10 μs).

The drivers operate off an internal supply voltage.

Connection and signals for the SSI interface :

Default count direction: UP when the motor shaft is rotating clockwise (looking at the end of the motor shaft)

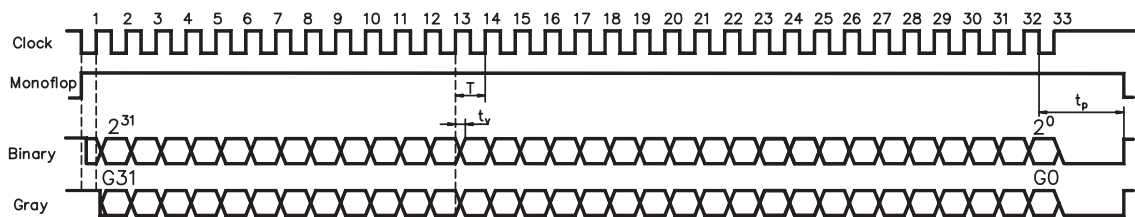
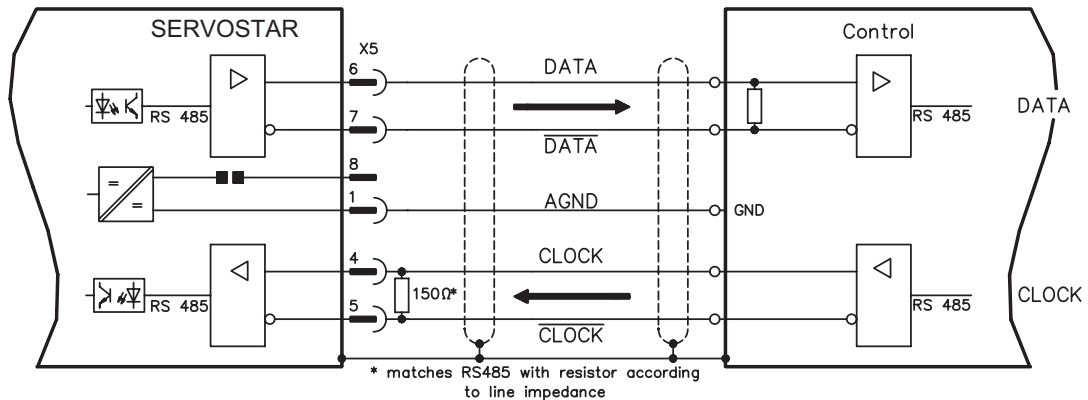

Switch over time Data  $t_v \leq 300\text{nsec}$   
 Period  $T = 600\text{ ns}$   
 Time Out  $t_p = 1.3\mu\text{s}/10\mu\text{s}$  (SSITOUT)

Output  $I_{\Delta U} \geq 2\text{V}/20\text{mA}$   
 Input  $I_{\Delta U} \geq 0.3\text{V}$

## 8.15 Digital and analog inputs and outputs

### 8.15.1 Analog inputs (X3)

The servo amplifier is fitted with two **programmable** differential inputs for analog setpoints. AGND (X3/7) must always be joined to the GND of the controls as a ground reference.

#### Technical characteristics

- Differential-input voltage max.  $\pm 10$  V
- Ground reference AGND, terminal X3/7
- Input resistance 2.4 k $\Omega$
- Common-mode voltage range for both inputs  $\pm 10$  V
- Update rate 62,5  $\mu$ s

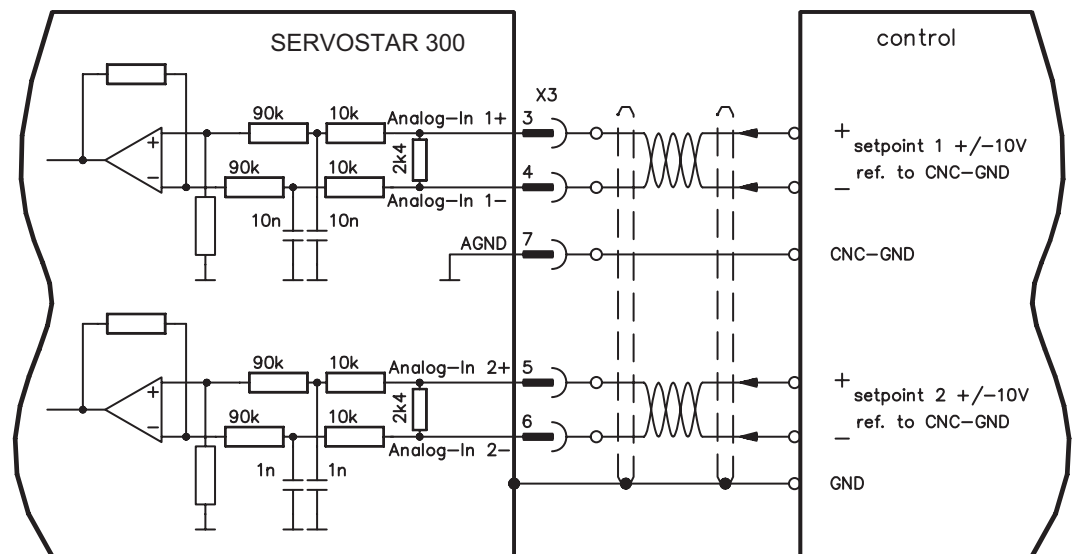

#### Analog-In 1 input (terminals X3/3-4)

Differential input voltage max.  $\pm 10$  V, resolution 14-bit, scalable.  
Standard setting : speed setpoint

#### Analog-In 2 input (terminals X3/5-6)

Differential input voltage max.  $\pm 10$  V, resolution 12-bit, scalable.  
Standard setting : torque setpoint

Application examples for setpoint input Analog-In 2:

- adjustable external current limit
- reduced-sensitivity input for setting-up/jog operation
- pre-control / override

#### Defining the direction of rotation

Standard setting : clockwise rotation of the motor shaft (looking at the shaft end)

- Positive voltage between terminal X3/3 (+) and terminal X3/4 (-) or
- Positive voltage between terminal X3/5 (+) and terminal X3/6 (-)

To reverse the direction of rotation, swap the connections to terminals X3/3-4 or X3/5-6 respectively, or change the ROTATION DIRECTION parameter in the "Speed controller" screen page.

## 8.15.2 Digital inputs (X3/X4)

All digital inputs are **electrically isolated** via optocouplers.

### Technical characteristics

- Ground reference is **Digital-GND** (DGND, terminals X4/3 and X4/4)
- The inputs at X3 are **PLC-compatible** (IEC 61131-2 Type 1)  
High: 11...30 V / 2...11 mA , Low: -3...5 V / <1 mA
- Update rate Software:250  $\mu$ s / Hardware: 2  $\mu$ s

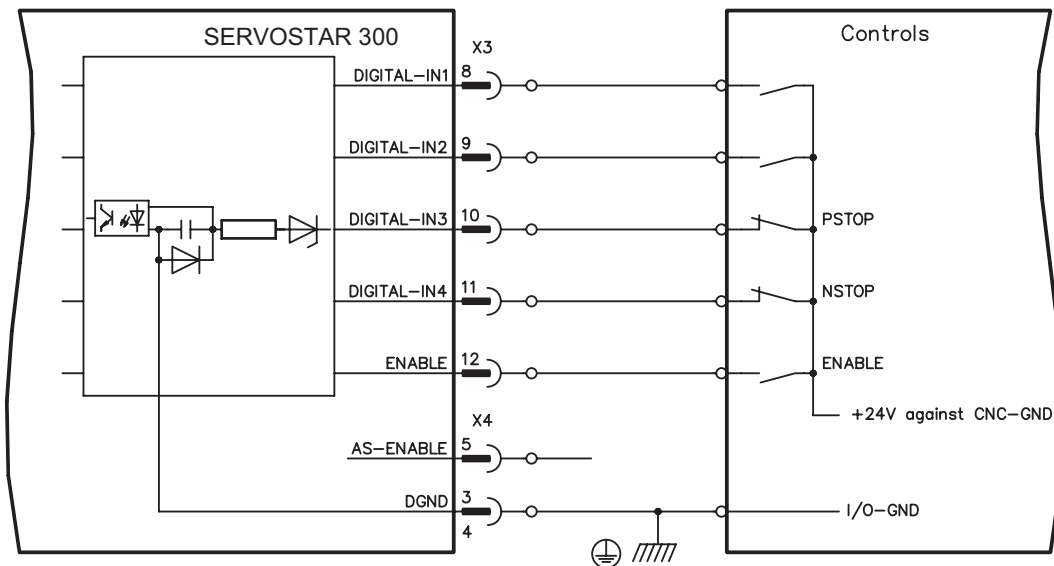

### ENABLE input

The output stage of the servo amplifier is enabled by applying the ENABLE signal (terminal X3/12, 24 V input, **active high**). Enable is possible only if input AS-Enable has a 24 V signal (see page 36ff).

In the disabled state (low signal) the connected motor has no torque.

### AS-ENABLE input

An additional digital input (AS-Enable) releases the power output stage of the amplifier as long as a 24 V signal is applied to this input. If the AS-Enable input goes open-circuit, then power will no longer be supplied to the motor, **the drive will lose all torque and coast down to a stop**. A fail-safe brake function for the drive, if one is required, must be ensured through a mechanical brake since electrical braking with the aid of the drive is no longer possible.

You can thus achieve a restart lock-out for personnel safety by using the AS-enable input in conjunction with an external safety circuit.

You can find further information and connection examples on page 36.



**This input is not compatible with IEC 61131-2.**

### Programmable digital inputs

You can use the DIGITAL-IN1 to DIGITAL-IN4 digital inputs to initiate pre-programmed functions that are stored in the servo amplifier. A list of these pre-programmed functions can be found on the "Digital I/O" screen page of our setup software.

If an input was freshly assigned to a pre-programmed function, then the data set must be saved in the EEPROM of the servo amplifier and a reset has to be carried out (with the amplifier setup software for example).

### 8.15.3 Digital outputs (X3)

#### Technical characteristics

- Ground reference is Digital-GND (DGND, terminals X4/3 and X4/4)
- All digital outputs are floating
- DIGITAL-OUT1 and 2 : Open Emitter, max. 30 V DC, 10 mA
- BTB/RTO : Relay output, max. 30 V DC or 42 V AC, 0.5 A
- Update rate 250  $\mu$ s

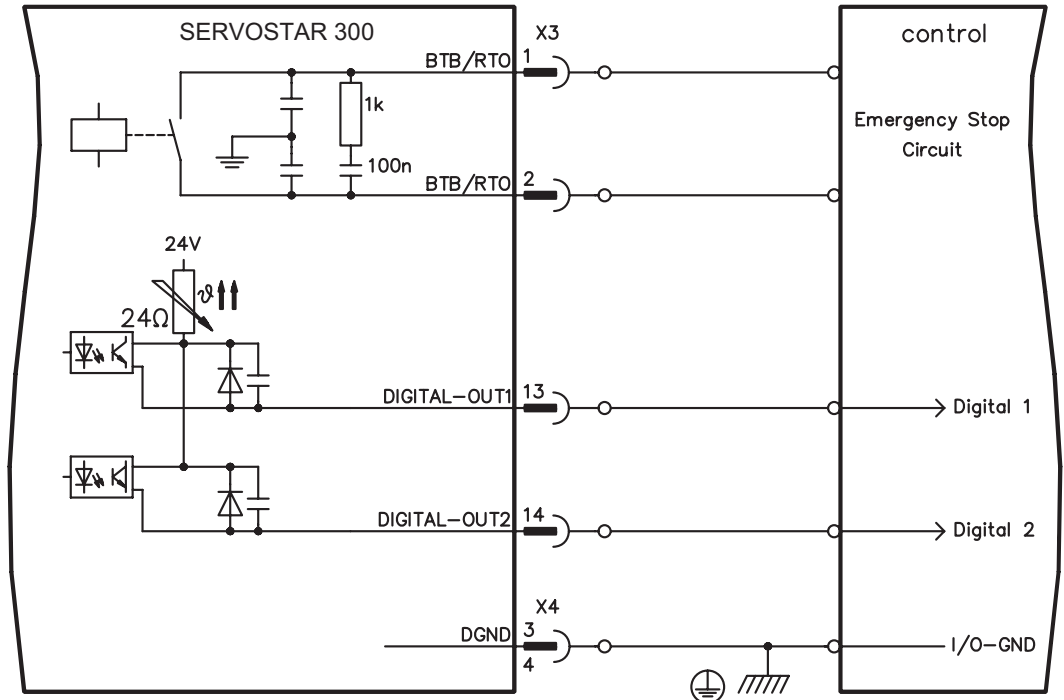

#### Ready-to-operate contact BTB/RTO

Operational readiness (terminals X3/1 and X3/2 ) is signaled by a **floating** relay contact. The contact is **closed** when the servo amplifier is ready for operation, and the signal is **not** influenced by the enable signal, the I<sup>2</sup>t-limit, or the brake threshold.



**All faults cause the BTB/RTO contact to open and the output stage to be switched off (if the BTB/RTO contact is open, the output stage is inhibited -> no power output). A list of the error messages can be found on page 104.**

#### Programmable digital outputs DIGITAL-OUT 1 / 2:

You can use the digital outputs DIGITAL-OUT1 (terminal X3/13) and DIGITAL-OUT2 (terminal X3/14) to output messages from pre-programmed functions that are stored in the servo amplifier.

A list of these pre-programmed functions can be found on the "I/O digital" screen page of our setup software.

If an output is to be freshly assigned to a pre-programmed function, then the parameter set must be saved in the EEPROM of the servo amplifier and a reset has to be carried out (with the amplifier setup software for example).

### 8.16 RS232 interface, PC connection (X6)

Operating, position control, and motion-block parameters can be set up by using the setup software on an ordinary commercial PC.

Connect the PC interface (X6) of the servo amplifier to a serial interface on the PC via a null-modem cable, **while the supply to the equipment is switched off.**



**Do not use a null-modem power link cable!**

This interface has the same electrical potential as the CANopen interface.

The interface is selected and set up in the setup software. Further notes on page 90.

With the optional -2CAN- expansion card, the two interfaces for RS232 and CAN, which would otherwise use the same connector X6, are separated out onto three connectors (⇒ p.120).

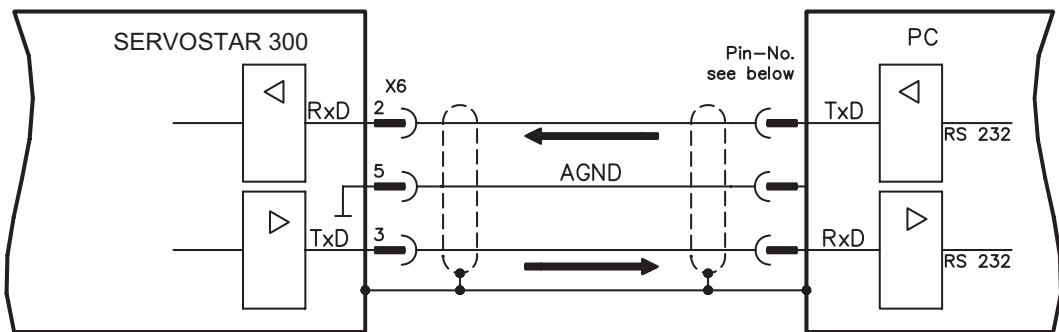

Interface cable between the PC and servo amplifiers of the SERVOSTAR 300 series:

(View : looking at the solder side of the SubD sockets on the cable)

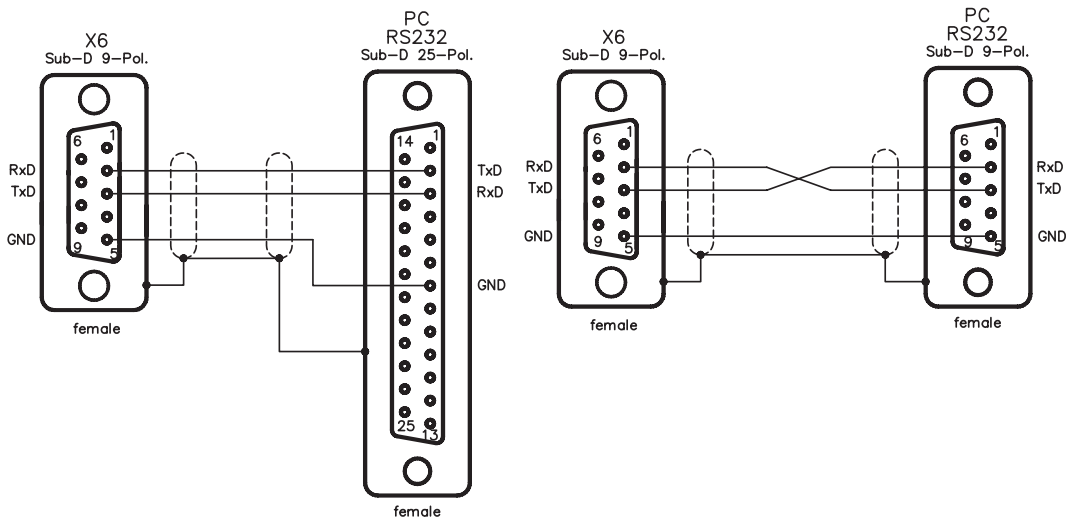

### 8.17 CANopen interface (X6)

The interface for connection to the CAN-bus (default : 500 kBaud). The integrated profile is based on the CANopen DS301 communication profile and the DS402 drive profile. The following functions are available in connection with the position controller: Jogging with variable speed, homing run (zeroing to reference), start motion task, start direct task, digital setpoint provision, data transmission functions and many others. Detailed information can be found in the CANopen manual. The interface is at the same electrical potential as the RS232 interface. The analog setpoint inputs can still be used. With the optional -2CAN- expansion card, the two interfaces for RS232 and CAN, which otherwise use the same connector X6, are separated out onto three connectors (with termination, ⇒ p.120).

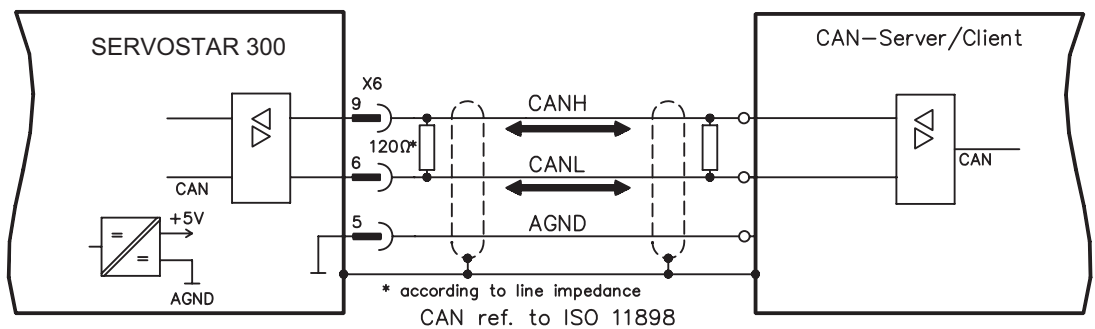

#### CAN-bus cable

To meet ISO 11898, a bus cable with a characteristic impedance of 120 Ω should be used. The maximum usable cable length for reliable communication decreases with increasing transmission speed. As a guide, you can use the following values which we have measured, but they are not to be taken as assured limits:

<b>Cable data:</b>	Characteristic impedance	100-120 Ω
	Cable capacitance	max. 60 nF/km
	Lead loop resistance	159.8 Ω/km

#### Cable length, depending on the transmission rate

Transmission rate (kBaud)	max. cable length (m)
1000	10
500	70
250	115

Lower cable capacitance (max. 30 nF/km) and lower lead resistance (loop resistance, 115 Ω/km) make it possible to achieve greater distances. (Characteristic impedance 150 ± 5 Ω ⇒ terminating resistor 150 ± 5 Ω).

For EMC reasons, the SubD connector housing must fulfill the following requirements:

- metal or metalized housing
- provision for cable shielding connection on the housing, large-area connection

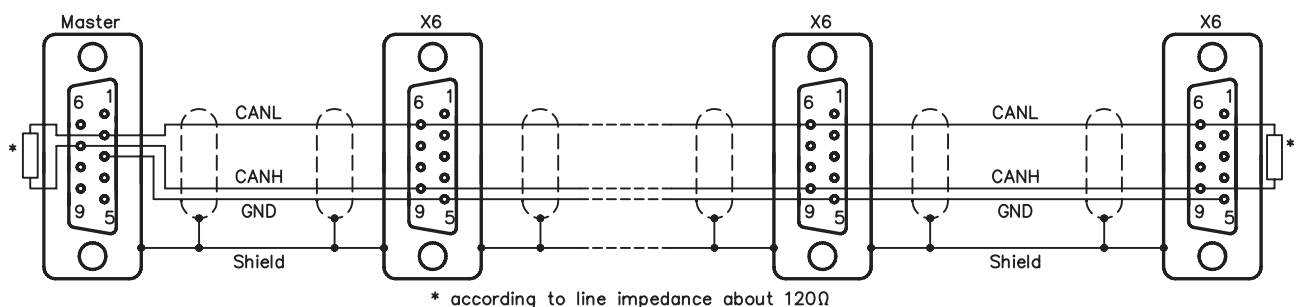

This page has been deliberately left blank.



## 9 Setup

The procedure for setup is described as an example. Depending on the application, a different procedure may be appropriate or necessary. In multi-axis systems, set up each servo amplifier individually.

### 9.1 Safety Instructions

**▲ DANGER** The equipment produces potentially lethal voltages up to 900 V. Check that all connection components that are live in operation are safely protected against bodily contact.

**▲ WARNING** Never undo the electrical connections to the servo amplifier while it is live. Capacitors can still have dangerous residual charges up to 300 seconds after switching off the supply voltage.

**▲ CAUTION** The heat sink and front panel of the amplifier can reach temperatures up to 80°C in operation. Check the heat sink temperature. Wait until the heat sink has cooled down to 40°C before touching it.

**▲ CAUTION** Before setting up, the manufacturer of the machine must generate a hazard analysis for the machine, and take appropriate measures to ensure that unforeseen movements cannot cause injury or damage to any person or property.

**▲ CAUTION** Only professional personnel with extensive knowledge in the fields of electrical engineering and drive technology are allowed to setup the servo amplifier.

**NOTICE** If the servo amplifier has been stored for more than 1 year, it will be necessary to re-form the capacitors in the DC bus link circuit. To do this, disconnect all electrical connections and apply single-phase 208...240 V AC to terminals L1 / L2 of the servo amplifier for about 30 minutes. This will re-form the capacitors.



Additional information on setting up the equipment:

The adaptation of parameters and the effects on the control loop behavior are described in the online help of the setup software.

The setting up of any expansion card that may be fitted is described in the corresponding manual on the CD-ROM.

We can provide further know-how through training courses (on request).

## 9.2 Setup software

### 9.2.1 General

This chapter describes the installation of the setup software DRIVEGUI.EXE for the SERVOSTAR 300 digital servo amplifiers.

We offer training and familiarization courses on request.

#### 9.2.1.1 Use as directed

The setup software is intended to be used for altering and saving the operating parameters for the SERVOSTAR 300 series of servo amplifiers. The attached servo amplifier can be set up with the help of this software, and during this procedure the drive can be controlled directly by the service functions.



**Only professional personnel who have the relevant expertise described on page 7 are permitted to carry out online parameter setting for a drive that is running. Sets of data that have been stored on data media are not safe against unintended alteration by other persons. After loading a set of data you must therefore always check all parameters before enabling the servo amplifier.**

#### 9.2.1.2 Software description

The servo amplifiers must be adapted to the requirements of your machine. Usually you will not have to carry out this parameter setting yourself on the amplifier, but on a PC, with the assistance of the setup software. The PC is connected to the servo amplifier by a null-modem cable (serial, see p.86). The setup software provides the communication between the PC and SERVOSTAR 300.

You can find the setup software on the accompanying CD-ROM and in the download area of our website.

With very little effort you can alter parameters and instantly observe the effect on the drive, since there is a continuous (online) connection to the amplifier. At the same time, important actual values are read out from the amplifier and displayed on the monitor of the PC (oscilloscope functions).

Any interface modules (expansion cards) which may be built into the amplifier are automatically recognized, and the additional parameters which are required for position control or motion-block definition are made available.

You can save sets of data on data media (archiving) and load them again. You can also print out the data sets.

We supply you with motor-specific default sets of data for the most common combinations of servo amplifier and motor. In most applications you will be able to use these default values to get your drive running without any problems.

An extensive online help with integrated description of all variables and functions supports you in each situation.

### 9.2.1.3 Hardware requirements

The PC interface (X6, RS232) of the servo amplifier is connected to the serial interface of the PC by a null-modem cable (**not a null-modem link cable!**) (⇒ p.86).

**NOTICE**

**Connect / disconnect the interface cable only when the electrical supply is switched off for both the PC and the servo amplifier.**

The interface in the servo amplifier has the same potential level as the CANopen interface.

**Minimum requirements for the PC:**

Processor	:	at least Pentium® II or comparable
Operating system	:	WINDOWS 2000 / XP
Graphics adapter	:	Windows compatible, color
Drives	:	hard disk with at least 10 MB free space CD-ROM drive
Interface	:	one free serial interface (COM1 ... COM10)

### 9.2.1.4 Operating systems

**WINDOWS 2000 / XP**

DRIVEGUI.EXE will run under WINDOWS 2000 and WINDOWS XP.

Emergency operation is feasible through an ASCII terminal emulation (without graphical user interface).

Interface settings : 38400 bps, databit 8, no parity, stopbit 1, no flow control

**Unix, Linux**

The functioning of the software has **not** been tested for WINDOWS running within Unix or Linux.

### 9.2.2 Installation under WINDOWS 2000 / XP

The CD-ROM includes an installation program for the setup software.

**Installation**

Autostart function activated:

Insert the CD-ROM into a free drive. A window with the start screen opens. There you find a link to the setup software DRIVEGUI.EXE. Click it and follow the instructions.

Autostart function deactivated:

Insert the CD-ROM into a free drive. Click on **START** (task bar), then on **Run**. Enter the program call: **x:index.htm** (x = correct CD drive letter).

Click **OK** and proceed as described above.

**Connection to the serial interface of the PC:**

Connect the interface cable to a serial interface on your PC (COM1 to COM10) and to the serial interface of the servo amplifier SERVOSTAR 300 (⇒ p.86).

## 9.3 Quickstart

### 9.3.1 Preparation

#### 9.3.1.1 Unpacking, Mounting and Wiring the Servo Amplifier

1. Unpack servo amplifier and accessories
2. **Observe safety instructions in the manuals**
3. Mount the servo amplifier as described in chapter 7
4. Wire the servo amplifier as described in chapter 8 or apply the minimum wiring for drive testing as described in chapter 9.3.1.3
5. Install the software as described in chapter 9.2

#### 9.3.1.2 Documents

You need access to these documents (located on the product CD-ROM, you can download the latest editions from our website):

- Product Manual (this manual)
- Accessories Manual
- CANopen communication profile Manual

Depending on the installed expansion card you need one of these documents:

- PROFIBUS DP communication profile Manual
- DeviceNet communication profile Manual
- SERCOS communication profile Manual
- EtherCat communication profile Manual

You need Acrobat Reader to read the PDFs, an installation link is on every screen of the product CD-ROM.

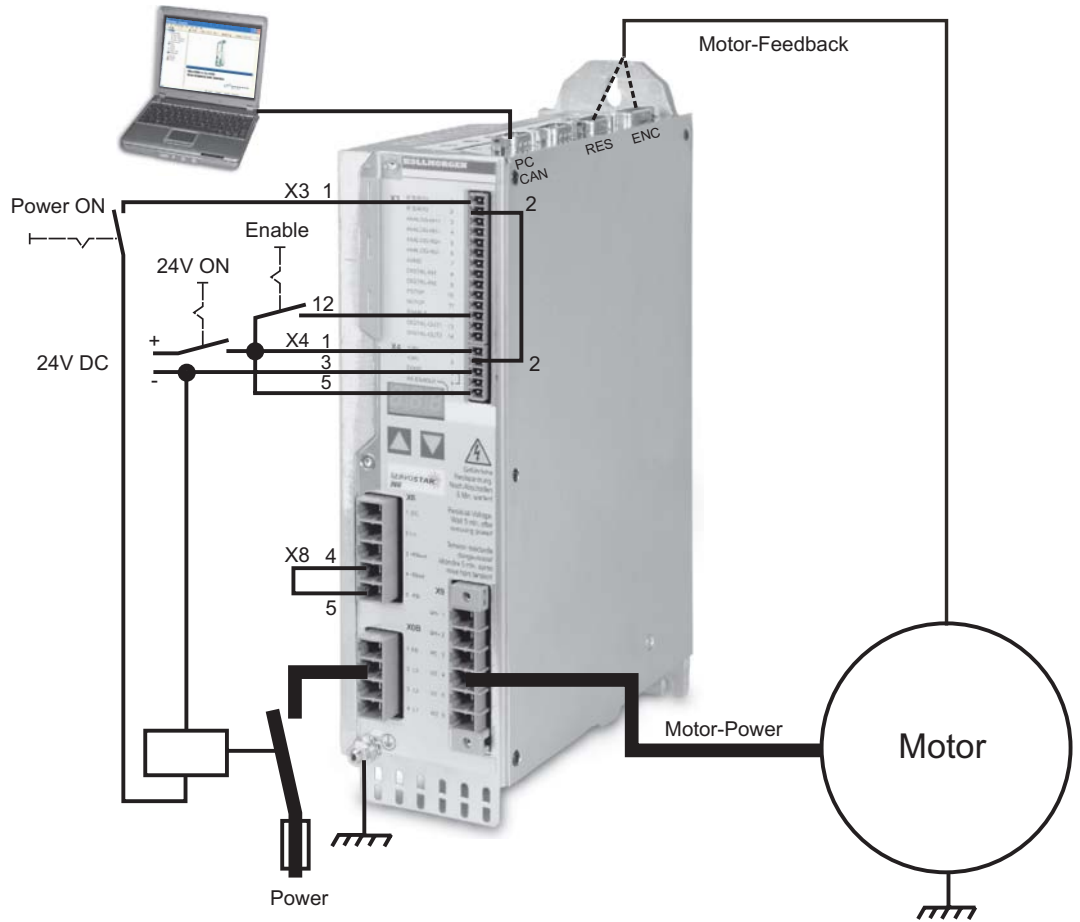

### 9.3.1.3 Minimum Wiring for Drive Test

**CAUTION** This wiring does not fulfill any requirements to safety or functionality of your application, it just shows the required wiring for drive testing without load.





## 9.3.2

## Connect

- Connect the interface cable to a serial interface on your PC and to the serial interface X6 of the servo amplifier. USB to serial converter can be used optionally.
- Switch on the 24 V power supply for the servo amplifier.
- Wait about 30 seconds, until the front display of the servo amplifier displays the current class (e.g.  for 3 A). If the power supply voltage is switched on, too, a leading P is displayed (e.g.  for Power, 3 A).



If a fault code () or a warning () or a status message (.I\_ / E/S) appears in the display, you will find the description on page 104 / 105. If there is fault, fix the problem.



Double-Click the DRIVEGUI.EXE icon on your Windows desktop to start the software.

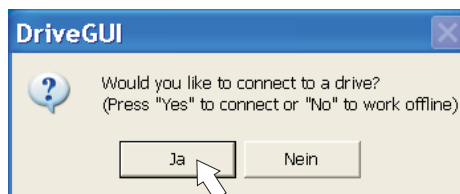

You can work offline or online with DRIVEGUI.EXE. Work ONLINE now.

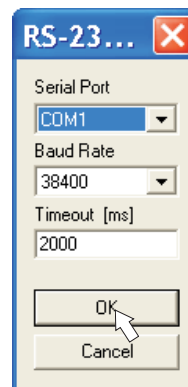
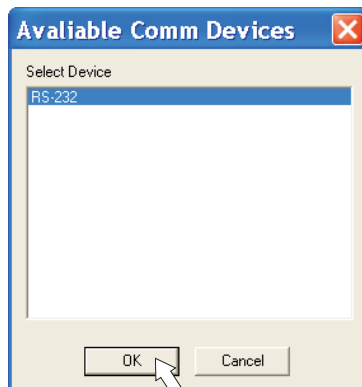

If the communication is started for the first time, you have to setup the communication parameters. Choose the communication system and the interface, where the servo amplifier is connected to. Click OK.

The software tries to communicate with these parameters. If it's not successful, you receive this error message:



Frequent causes:

- wrong interface chosen
- wrong connector chosen at the servo amplifier
- interface is used by another software
- 24 V auxiliary voltage for the servo amplifier not working
- interface cable broken or wrong wiring

Quit the error message. The software starts in the offline mode now, that requires the manual selection of the amplifier's type. Quit this selection by closing the window. Fix the communication problem. Restart the software in Online mode.

If communication works, you see the start screen. Select "Setup Wizard" in the navigation frame.

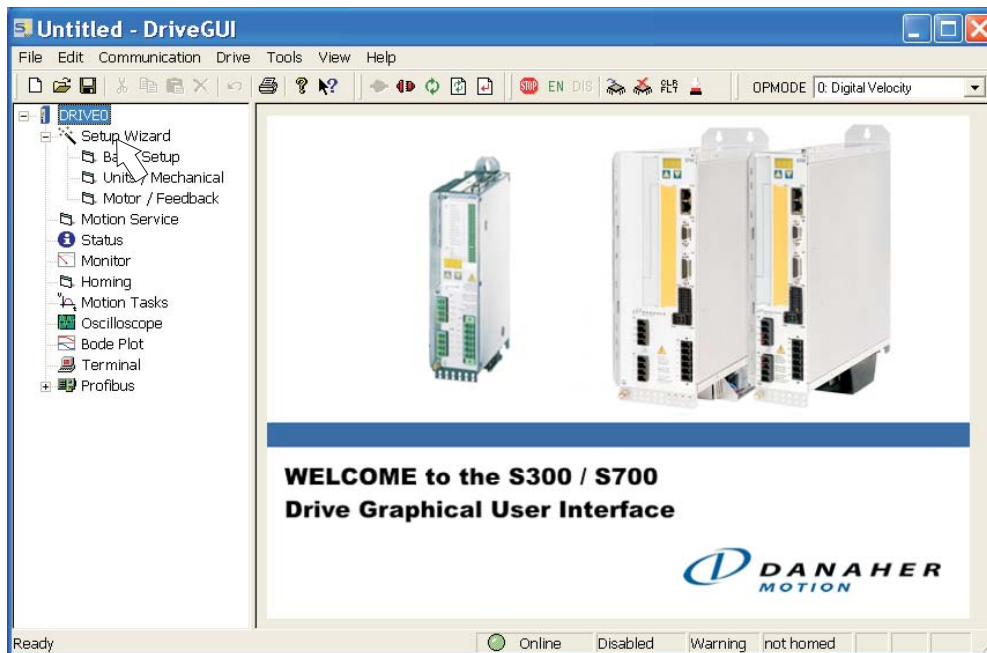

**NOTICE**

Make sure, that the amplifier is disabled (Input Enable connector X3 pin 12 must be 0 V or open)!



**9.3.3 Important Screen Elements**

**Help Function**

The Online-Help gives detailed information to all parameters the servo amplifier can work with.

<b>Key F1</b>	Starts Online Help for the actual screen page.
<b>Menu bar Help</b>	Starts Online Help with the first page.
	Context Help. Click the help symbol first. Then click the function for which you need help.

**Tool Bar**

	
	Save to EEPROM, required if you changed parameters.
	Reset, required if you changed configuration parameters.
OPMODE 0: Digital Velocity	Operation Mode, use "0: Digital Velocity" mode for drive testing.

**Status Bar**

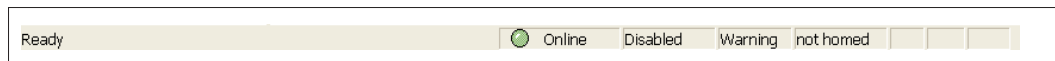

The status bar shows a green Online symbol, indicating that the communication works.

### 9.3.4 Setup Wizard

The Setup Wizard leads you through the necessary steps for configuring your servo amplifier. Depending on the selected application, only the active screen pages are necessary.



For a quick setup / drive test, select the setup type "Quick Motor/Drive Setup".

**Start the Wizard.**

#### 9.3.4.1 Basic Setup

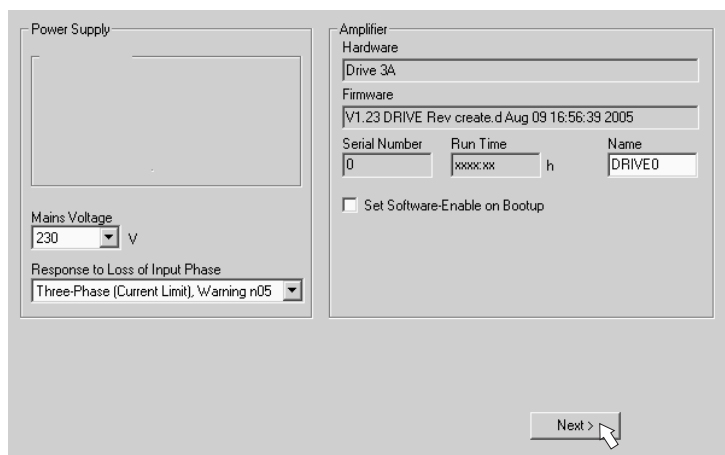

Basic parameters are setup here.

**Response to Loss of Input Phase:** Select Single-Phase or Three-Phase operation. With three-phase operation you can select either warning "n05" or error "F19" in case of phase loss. The reaction "F19" disables the output stage, "n05" is just a message.

**Name:** You can enter a name for the servo amplifier (up to 8 characters). This simplifies the drive identification in the system.

**Set Software Enable on Bootup:** Don't select this option for the quick test.

**Click NEXT.**



### 9.3.4.2 Units/Mechanical

The user units for all input fields in the setup software can be preselected here.

#### Position, Velocity, Acceleration

Select usable units for your application referring to the moved load.

#### Mechanical Conversion

The relationship between motor shaft revolution (pole pair pitch with linear motors) and motion distance of the load is specified here. Gear ratio can be calculated here as well. Detailed information can be found in the online help.

Use the tool based on sample applications for calculating the resolution value:

#### Calculate PGEARI/PGEARO for..." button

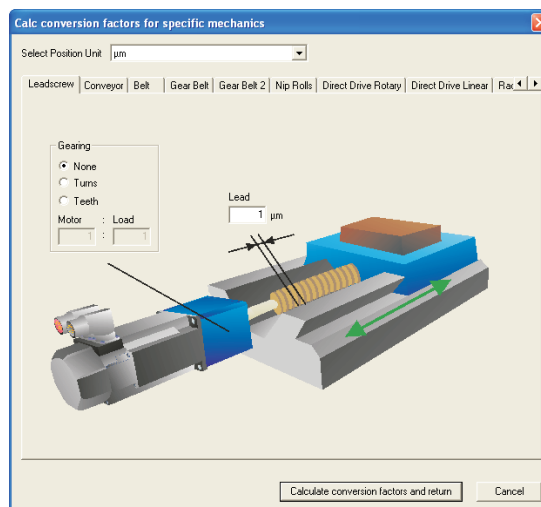

If your application does not correspond to any of the listed examples, enter the required parameters directly in the fields on the "Units" screen.

First, select the application that corresponds to your own. Next, set the position unit. Select the position unit that provides you with the required accuracy for your application. Set the mechanical data for your application now. If a gearhead is flange-mounted on the motor, you must also enter the gearhead data (either the number of teeth or the ratio of the revolutions).

Then click the "Calculate conversion factors and return" button.

**Click NEXT.**

### 9.3.4.3 Motor (rotary) / Feedback

Simplified setting of the motor related parameters.



**Feedback:** Select the feedback system used in the motor.

**Attention: Resolver is fixed to 2 pole in the Quick Motor/Drive Setup.**

Change "pole n" on feedback screen in Complete Setup later, if required.

**Motor type:** Click the button "Select from Database...".

Open the database file (mdb\_\*.csv) and select the used motor out of the list. Special motors must be defined in the "Complete Setup".

**Brake:** If the amplifier shall control a brake, change the Brake parameter to "With"

**Calculated quick tuning:** If you know the Load-to-motor inertia ratio (0 is for no load), enter the number here and select the desired servo performance. If you don't know the inertia ratio, select "Do not tune". **Click FINISH.**

### 9.3.4.4 Motor (linear) / Feedback (Encoder)

Simplified setting of the motor related parameters.

**Feedback:** Select the feedback system used.

**Motor type:** Click the button "Select from Database..".

Open the database file (mdb\_\*.csv) and select the used motor. Special motors must be defined in the "Complete Setup".

**Encoder Lines** (appears with Feedback Type Sine Encoder):

Click "Calculate" and fill in the Encoder signal period.

**Brake:** If the amplifier shall control a brake, change the Brake parameter to "With"

**Calculated quick tuning:** If you know the Load-to-motor inertia ratio, enter the number here and select the desired servo performance. Otherwise select "Do not tune".

**Click FINISH.**

### 9.3.4.5 Save Parameters and Restart

You are going to finish the Setup Wizard and you have changed several basic parameters. Depending on the parameters you changed, two possible reactions will occur now:

#### Configuration parameters changed

A warning appears, that you have to restart the amplifier, this is called "coldstart".

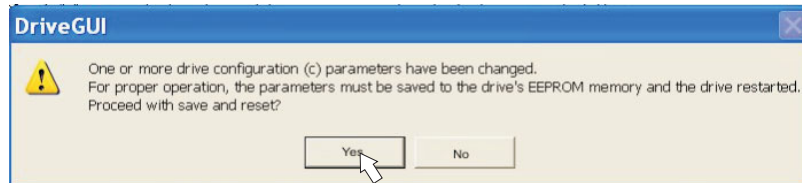

Click "YES".

The parameters are saved to the amplifier's EEPROM automatically and a reset command restarts

the amplifier (takes some seconds).

#### Other parameters changed





No warning appears. Save the parameters to the EEPROM of the servo amplifier manually by clicking the symbol  in the tool bar. A coldstart of the amplifier is not necessary.

Select the screen "Motion Service" in the navigation frame.

### 9.3.5 Motion Service (Jog Mode)

#### NOTICE

**Be aware that the actual position of the load permits the subsequent moving operations. The axis could move to the hardware limit-switch or the mechanical stop. Make sure that a jerk or a fast acceleration of the load cannot cause any damage.**

- Switch on the power supply for the drive.
- **AS-Enable:** Apply +24 V to the input AS-Enable [X4/5]
- **Hardware-Enable:** Apply +24 V to the input Enable [X3/12]. If AS-Enable is missed or the sequence was wrong, the front display shows .
- **Software-Enable:** Click the symbol  in the tool bar. Now the front display shows an E and the current class (e.g.  for Enable, 3 A). Click the symbol  to switch off the output stage (disable).

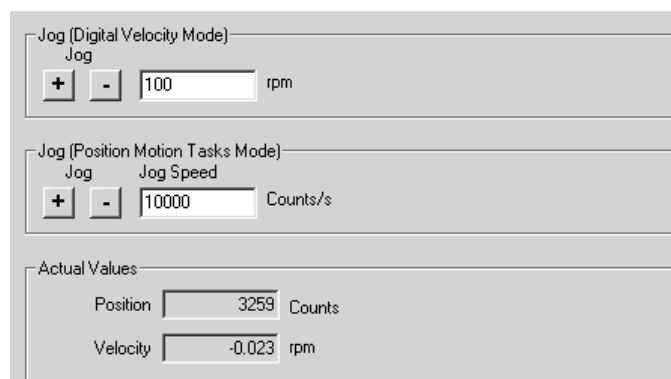

#### Jog

##### (Digital Velocity Mode):

You can move the drive with constant speed. Enter the desired speed.

**CAUTION: Observe the "safe reduced speed" requirements for your application!**

The drive moves with the preset speed when the + or – button is pressed. It stops when the button is released.

Actual errors and warnings are listed on the screen "Status". A description of errors/warnings can be found in the online help or on p.104ff.

Now you have setup and tested the basic functions of the drive successfully.

### 9.3.6 More Setup Screens



**Observe the safety instructions in the manuals and in the online help before you change parameters in the additional setup screens.**

For all setup functions detailed information can be found in the Online Help system and the integrated command reference.

Select "Complete Setup" in the Setup-Wizard. Now you have access to:

- **Feedback:** Adjust the used feedback unit
- **Motor:** Adjust the used motor
- **Control Loops:** Current-, Velocity- and Position-Loops can be optimized
- **Position Data:** Adjust the position control for the requirements of your application.
- **Position Registers:** up to 16 position values in the motion way can be monitored.
- **Electronic Gearing:** If the servo amplifier will follow a setpoint as a slave with a gear ratio, you can select the gearing source here and define the gear ratio.
- **Encoder Emulation:** select the encoder emulation (position output)
- **Analog I/O:** setup the analog inputs
- **Digital I/O:** setup the digital inputs and outputs
- **Status (Errors/Warnings):** displays amplifiers data with history, actual faults/warnings
- **Monitor:** displays the drive data (actual values)
- **Homing:** definition and start of homing
- **Motion task:** definition and start of motion task
- **Oscilloscope:** 4 channel oscilloscope with multiple functionality
- **Bode Plot:** tool for optimizing the drive
- **Terminal:** setup the servo amplifier with ASCII commands
- **Expansion Card:** depending on the built-in expansion card a menu appears

## 9.4 Multi-axis systems

### 9.4.1 Station address for CAN-bus

You can use the keypad on the front panel to preset the station addresses for the individual amplifiers and the baud rate for communication (⇒ p.103). Usually the setup software is used to set all parameters.

### 9.4.2 Baud rate for CAN-bus



After changing the station address and baud rate you must turn the 24V auxiliary supply for the servo amplifier off and on again.

#### Coding of the Baud rate in the LED display :

Coding	Baud rate in kbit/s	Coding	Baud rate in kbit/s
1	10	25	250
2	20	33	333
5	50	50	500
10	100	66	666
12	125	80	800
		100	1000

## 9.5 Keypad operation / LED display

This section illustrates the two possible operating menus and the use of the keys on the front panel. Normally, the SERVOSTAR 300 only presents the standard menu for your use. If you want to operate the amplifier via the detailed menu, you must keep the right key pressed while switching on the 24V supply.

### 9.5.1 Keypad operation

The two keys can be used to perform the following functions:

Key symbol	Functions
	<b>press once</b> : move up one menu item, increase number by one <b>press twice in rapid succession</b> : increase number by ten
	<b>press once</b> : decrease number by one <b>press twice in rapid succession</b> : decrease number by ten
	<b>hold right key pressed, and then press left key as well</b> : to enter a number, "Return" function

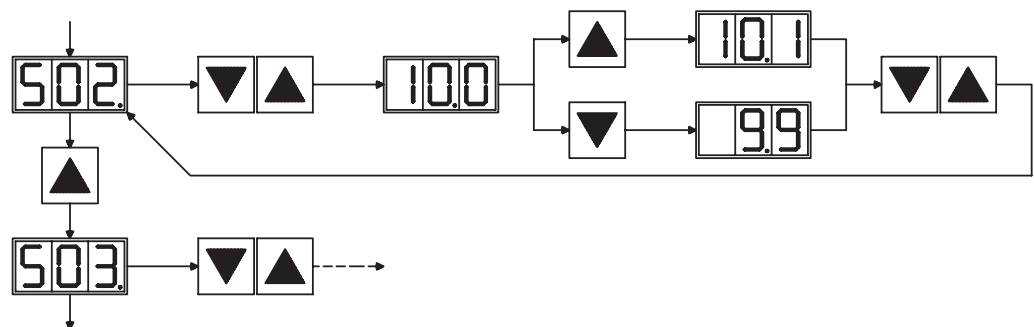

9.5.2 Status display

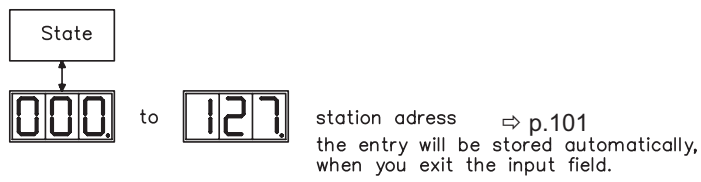

9.5.3 Standard menu

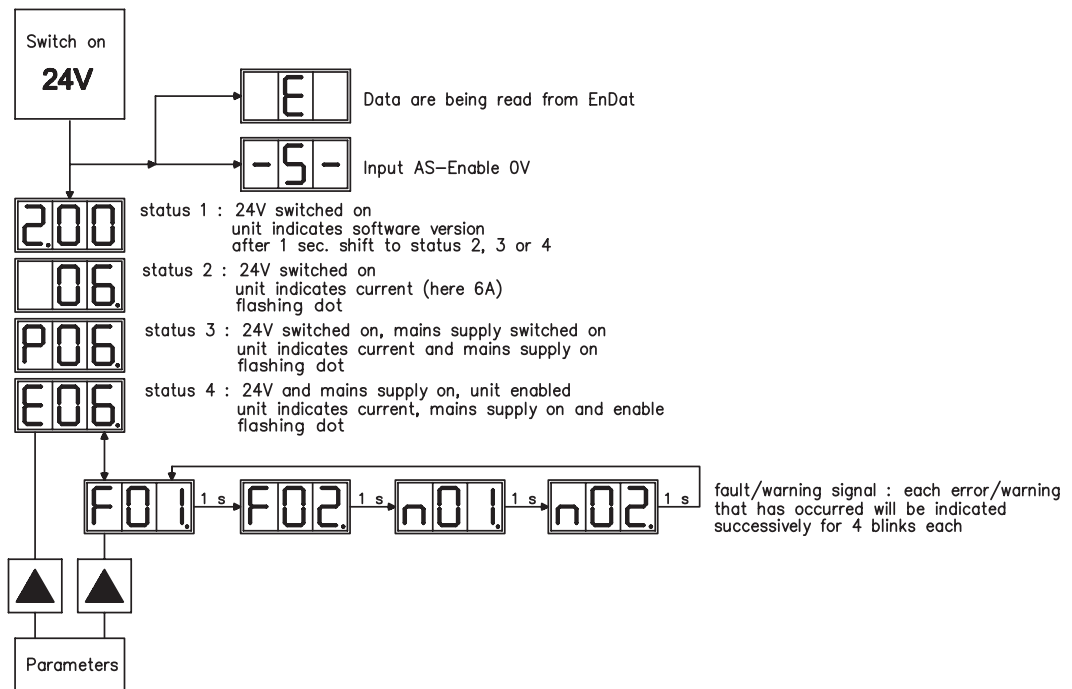

9.5.4 Advanced menu



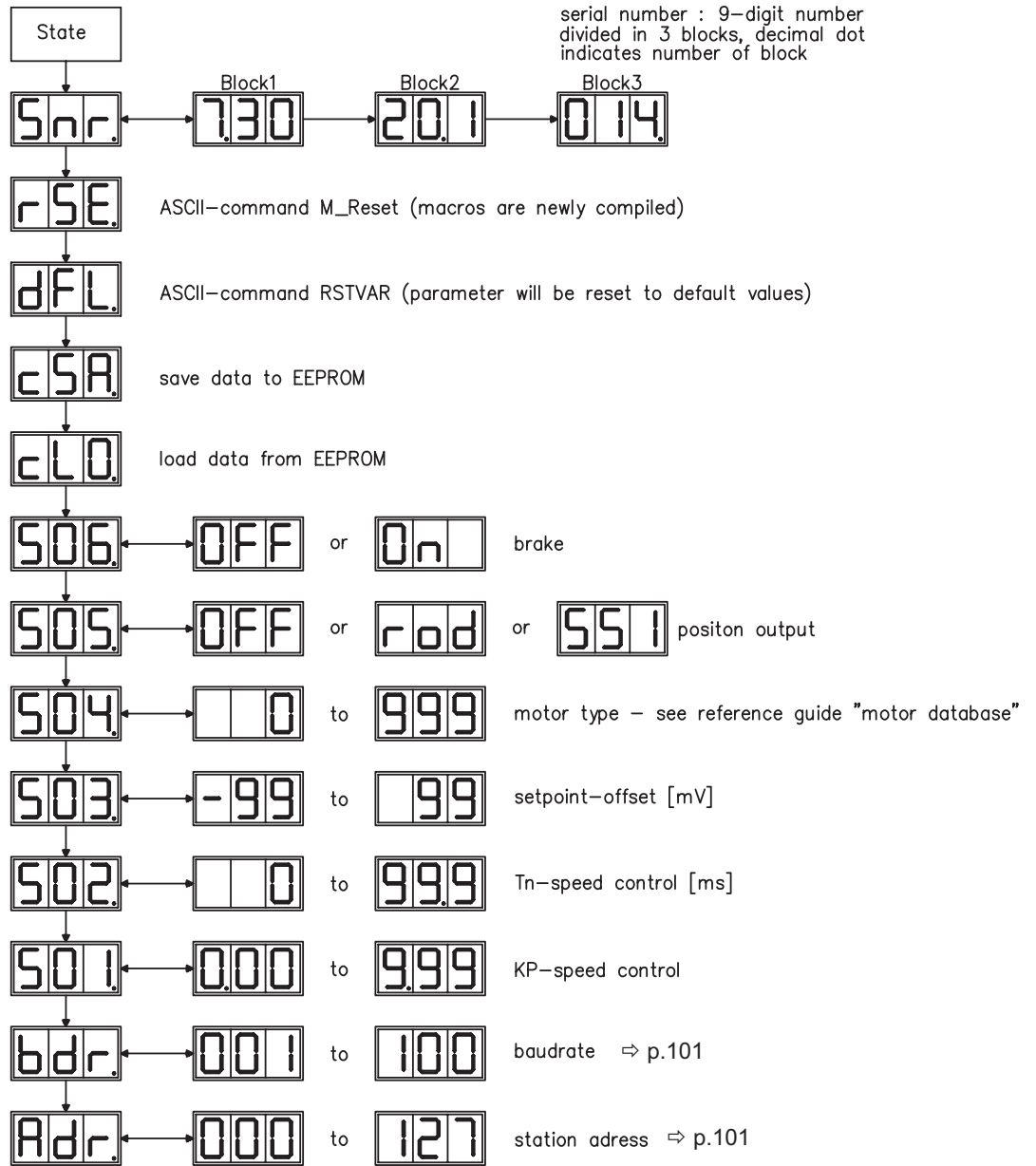

To operate the amplifier via the advanced menu, you must keep the right key pressed while switching on the 24 V supply.



## 9.6 Error messages

Any errors that occur are shown in coded form by an error number in the LED display on the front panel. All error messages result in the BTB/RTO contact being opened, the output stage being switched off (motor loses all torque), and the holding brake is activated.

Number	Explanation	
E / P	Status Messages	Status messages, no error, see p. 102
. . .	Status Message	Amplifier is updating the startup configuration
-	Status Message	Status message, no error, programming mode
- S -	AS-Enable	AS-Enable input is 0V (with disabled drive only)
F01*	Heat Sink Temperature	Heat sink temperature too high (default: 80°C)
F02*	Overvoltage	Overvoltage in DC bus link. Limit depends on the electrical supply voltage
F03*	Following Error	Message from the position controller
F04	Feedback	Cable break, short-circuit, short to ground
F05*	Undervoltage	Undervoltage in DC bus link (default: 100 V)
F06*	Motor Temperature	Motor temperature too high or temp. sensor defect
F07	Internal Voltages	Internal supply voltages not ok
F08*	Overspeed	Motor runs away, speed is too high
F09	EEPROM	Checksum error
F10	Signal Failure X5	Signal failure X5 (cable break or similar)
F11	Brake	Cable break, short-circuit, short to ground
F12	Motor Phase	Motor phase missing (cable break or similar)
F13*	Ambient Temperature	Ambient temperature too high
F14	Output Stage	Fault in the power output stage
F15	I <sup>2</sup> t max.	I <sup>2</sup> t maximum value exceeded
F16*	Mains BTB/RTO	2 or 3 phases missing in the mains supply feed
F17	A/D Converter	Error in the analog-digital conversion, normally caused by extreme electromagnetic interference
F18	Brake Circuit	Brake circuit faulty or incorrect setting
F19*	DC Bus Link	DC bus link breakdown
F20	Slot Error	Slot error, depends on the type of expansion card (see ASCII object reference)
F21	Handling Error	Handling error on the expansion card
F22	Reserved	Reserved
F23	CAN-Bus Off	Severe CAN bus communication error
F24	Warning	Warning is displayed as fault
F25	Commutation Error	Commutation error
F26	Limit Switch	Hardware limit switch error on homing move
F27	AS	Operational error with -AS-, input for AS-Enable and ENABLE have been set at the same time
F28	Fieldbus Error	Fieldbus error (see ASCII command reference)
F29	Fieldbus Error	Fieldbus error (see ASCII command reference)
F30	Emergency Timeout	Timeout emergency stop
F31	Reserve	Reserve
F32	System Error	System software not responding correctly

\* = these error messages can be cleared without a reset, by using the terminal screen and sending the ASCII command CLRFAULT (or button ). If only one of these errors is present and the RESET button  or the I/O RESET function is used, only the CLRFAULT command will be executed.



More information to the messages can be found in the ASCII Object Reference (Online Help), see parameter ERRCODE. Hints for removal can be found in the Online help chapter "Trouble-Shooting".



## 9.7 Warning messages

Faults which occur, but which do not cause a switch-off of the amplifier output stage (BTB/RTO contact remains closed), are indicated in the LED display on the front panel by a coded warning number.

Number	Designation	Explanation
<b>E / P</b>	Status Messages	Status messages, no error, see p. 102
. . .	Status Message	Amplifier is updating the startup configuration
<b>- S -</b>	AS-Enable	AS-Enable input is 0V (with disabled drive only)
-	Status Message	Status message, no error, programming mode
<b>n01</b>	I <sup>2</sup> t	I <sup>2</sup> t threshold exceeded
<b>n02</b>	Brake power	Reached preset brake power limit
<b>n03*</b>	S fault	Exceeded preset following error limit
<b>n04*</b>	Response monitoring	Response monitoring (fieldbus) has been activated
<b>n05</b>	Supply phase	Mains supply phase missing
<b>n06*</b>	SW limit switch 1	Software limit switch 1 underrun
<b>n07*</b>	SW limit switch 2	Software limit switch 2 overrun
<b>n08</b>	Motion task error	A faulty motion task was started
<b>n09</b>	No reference point	No reference point (Home) set at start of motion task
<b>n10*</b>	PSTOP	PSTOP limit-switch activated
<b>n11*</b>	NSTOP	NSTOP limit-switch activated
<b>n12</b>	Motor default values loaded	Only for ENDAT or HIPERFACE <sup>®</sup> : discrepancy between motor number saved in the encoder and the amplifier, motor default values loaded
<b>n13*</b>	Expansion card	24V DC supply for I/O expansion card not ok
<b>n14</b>	SinCos feedback	SinCos commutation (wake & shake) not completed, will be canceled when amplifier is enabled and wake & shake carried out
<b>n15</b>	Reserve	Reserve
<b>n16</b>	Summarized warning	Summarized warning for n17 to n31
<b>n17</b>	Fieldbus-sync	CAN sync is not logged in
<b>n18</b>	Multiturn overflow	Max. number of motor turns exceeded
<b>n19</b>	Motion task ramps are limited	Range overflow on motion task data
<b>n20</b>	Invalid motion task	Invalid motion task
<b>n21</b>	PLC program error	For details see PLC code
<b>n22</b>	Max. motortemperatur reached	The user can shut down the process before the temperature error will interrupt the process immediately
<b>n23</b>	Sin Cos feedback	Warning level reached
<b>n24</b>	Digital I/O	Configuration is not logical
<b>n25-n31</b>	Reserve	Reserve
<b>n32</b>	Firmware beta version	Firmware is an unreleased beta version

\* = these warning messages result in a controlled shut-down of the drive (braking by emergency stop ramp)



**More information to the messages can be found in the ASCII Object Reference (Online Help), see parameter STATCODE. Hints for removal can be found in the Online help chapter "Trouble-Shooting".**

## 9.8 Trouble Shooting

There may be a wide variety of reasons for the fault, depending on the conditions in your installation. In multi-axis systems there may be further hidden causes of a fault.



Detailed hints for removal of faults can be found in the Online help chapter "Trouble-Shooting".

Our customer service can give you further assistance with problems.

Fault	Possible causes	Measures
<b>HMI message: Communication fault</b>	<ul style="list-style-type: none"> <li>— wrong cable used</li> <li>— cable plugged into wrong position on servo amplifier or PC</li> <li>— wrong PC interface selected</li> </ul>	<ul style="list-style-type: none"> <li>— use null-modem cable</li> <li>— plug cable into the correct sockets on the servo amplifier and PC</li> <li>— select correct interface</li> </ul>
<b>Motor does not rotate</b>	<ul style="list-style-type: none"> <li>— servo amplifier not enabled</li> <li>— software enable not set</li> <li>— break in setpoint cable</li> <li>— motor phases swapped</li> <li>— brake not released</li> <li>— drive is mechanically blocked</li> <li>— motor pole no. set incorrectly</li> <li>— feedback set up incorrectly</li> </ul>	<ul style="list-style-type: none"> <li>— apply ENABLE signal</li> <li>— set software enable</li> <li>— check setpoint cable</li> <li>— correct motor phase sequence</li> <li>— check brake control</li> <li>— check mechanism</li> <li>— set motor pole no.</li> <li>— set up feedback correctly</li> </ul>
<b>Motor oscillates</b>	<ul style="list-style-type: none"> <li>— gain is too high (speed controller)</li> <li>— feedback cable shielding broken</li> <li>— AGND not wired up</li> </ul>	<ul style="list-style-type: none"> <li>— reduce Kp (speed controller)</li> <li>— replace feedback cable</li> <li>— join AGND to CNC-GND</li> </ul>
<b>Drive reports following error</b>	<ul style="list-style-type: none"> <li>— <math>I_{rms}</math> or <math>I_{peak}</math> set too low</li> <li>— accel/decel ramp is too long</li> </ul>	<ul style="list-style-type: none"> <li>— increase <math>I_{rms}</math> or <math>I_{peak}</math> (keep within motor ratings!)</li> <li>— shorten ramp +/-</li> </ul>
<b>Motor over-heating</b>	<ul style="list-style-type: none"> <li>— <math>I_{rms}/I_{peak}</math> is set too high</li> </ul>	<ul style="list-style-type: none"> <li>— reduce <math>I_{rms}/I_{peak}</math></li> </ul>
<b>Drive too soft</b>	<ul style="list-style-type: none"> <li>— Kp (speed controller) too low</li> <li>— Tn (speed controller) too high</li> <li>— ARLPF / ARHPF too high</li> <li>— ARLP2 too high</li> </ul>	<ul style="list-style-type: none"> <li>— increase Kp (speed controller)</li> <li>— use motor default value for Tn (speed controller)</li> <li>— reduce ARLPF / ARHPF</li> <li>— reduce ARLP2</li> </ul>
<b>Drive runs roughly</b>	<ul style="list-style-type: none"> <li>— Kp (speed controller) too high</li> <li>— Tn (speed controller) too low</li> <li>— ARLPF / ARHPF too low</li> <li>— ARLP2 too low</li> </ul>	<ul style="list-style-type: none"> <li>— reduce Kp (speed controller)</li> <li>— use motor default value for Tn (speed controller)</li> <li>— increase ARLPF / ARHPF</li> <li>— increase ARLP2</li> </ul>
<b>Axis drifts at setpoint = 0V</b>	<ul style="list-style-type: none"> <li>— offset not correctly adjusted for analog setpoint provision</li> <li>— AGND not joined to the controller-GND of the controls</li> </ul>	<ul style="list-style-type: none"> <li>— adjust offset (analog I/O)</li> <li>— join AGND and controller-GND</li> </ul>

## 10 Expansions Cards

You can find information about availability and order numbers on page 125.  
**Expansions cards can only be built into amplifiers without option FAN!**

### 10.1 Guide to installation of expansion cards

- Use a suitable screwdriver to lever off the cover of the option slot.

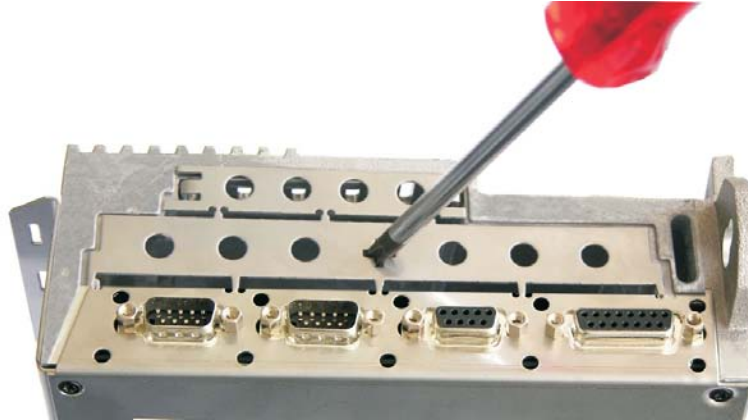

- Take care that no small items (such as screws) fall into the open option slot.
- Lever off the small metal sheet and push it back to the small slot. Dispose the big metal sheet.

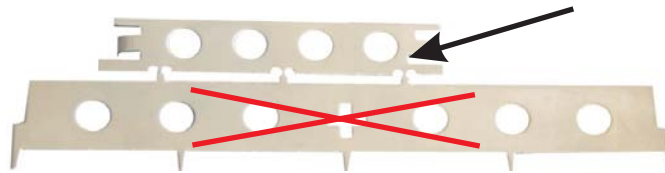

- Push the expansion card carefully into the provided guide rails of the main slot, without twisting it.
- Press the expansion card firmly into the slot.

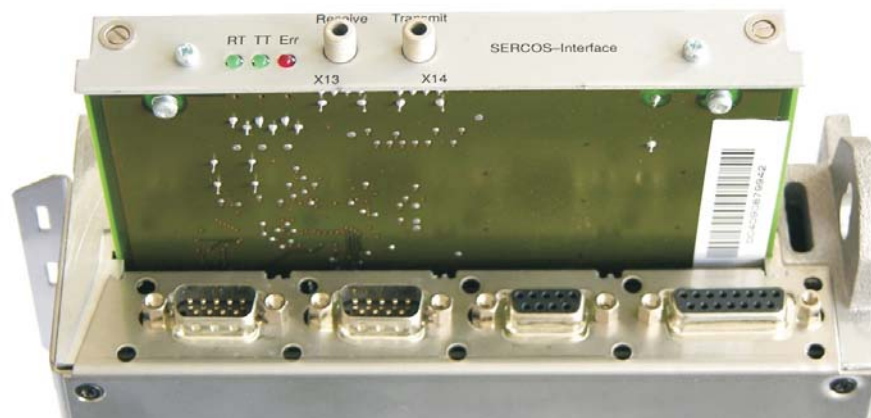

- Screw the screws on the front cover into the threads in the fixing lugs. This ensures that the connectors make good contact.

## 10.2 Expansion card -I/O-14/08-

This section describes the additional features that the expansion card -I/O-14/08- provides for the SERVOSTAR 300. If you ordered the expansion card together with the servo amplifier, then it will be delivered already inserted into the expansion slot of the servo amplifier and screwed in place.

The -I/O-14/08- provides you with 14 additional digital inputs and 8 digital outputs. The functions of the inputs and outputs are adjustable with the setup software.

The I/Os are used to initiate the motion tasks that are stored in the servo amplifier and to evaluate signals from the integrated position control in the higher-level control system. The functions of the inputs and signal outputs correspond to the functions that can be assigned to the digital I/Os on connector X3. All inputs and outputs are electrically isolated from the servo amplifier by optocouplers.

### 10.2.1 Front view



### 10.2.2 Technical data



<b>Control inputs</b>	24V / 7mA , PLC-compatible, IEC 1131
<b>Signal output</b>	24V / max. 500mA , PLC-compatible, IEC 1131
<b>Supply inputs, to IEC 1131</b>	24V (18 ... 36V) / 100mA plus total current of the outputs (depends on the input wiring of the controls) <b>The 24V DC voltage must be supplied by an electrically isolated power supply (e.g. with isolating transformer).</b>
<b>Fusing (external)</b>	4 AT
<b>Connectors</b>	MiniCombicon, 12-pin, coded on PIN1 and 12
<b>Cables</b>	Data – up to 50m long : 22 x 0.5 mm <sup>2</sup> , unshielded, Supply– 2 x 1mm <sup>2</sup> , check voltage drop
<b>Waiting time between 2 motion tasks</b>	depends on the response time of the control system
<b>Addressing time (minimum)</b>	4ms
<b>Starting delay (maximum)</b>	2ms
<b>Response time of digital outputs</b>	max. 10ms

### 10.2.3 LEDs

Two LEDs are mounted next to the terminals on the expansion card. The green LED signals that the 24V auxiliary supply is available for the expansion card. The red LED signals faults in the outputs from the expansion card (overload of switching components, short-circuit).

### 10.2.4 Entering a motion block number (example)

<b>Motion block number</b>	<b>A7</b>	<b>A6</b>	<b>A5</b>	<b>A4</b>	<b>A3</b>	<b>A2</b>	<b>A1</b>	<b>A0</b>
binary 1010 1110	1	0	1	0	1	1	1	0
decimal 174	128	-	32	-	8	4	2	-

### 10.2.5 Connector assignments

The functions are adjustable with the setup software. In the table below the default values are described.

Connector X11A			
Pin	Dir	Default function	Description
1	In	A0	Motion block number, LSB
2	In	A1	Motion block number, 2 <sup>1</sup>
3	In	A2	Motion block number, 2 <sup>2</sup>
4	In	A3	Motion block number, 2 <sup>3</sup>
5	In	A4	Motion block number, 2 <sup>4</sup>
6	In	A5	Motion block number, 2 <sup>5</sup>
7	In	A6	Motion block number, 2 <sup>6</sup>
8	In	A7	Motion block number, MSB
9	In	Reference	Polls the home switch. If a digital input on the base unit is used as a home input, then the input on the expansion card will <b>not</b> be evaluated.
10	In	F_error_clear	Clears the warning of a following error (n03) or the response monitoring (n04)
11	In	Start_MT_Next	The following task, that is defined in the motion task by "Start with I/O" is started. The target position of the present motion task must be reached before the following task can be started. The next motion block can also be started by an appropriately configured digital input on the base unit.
12	In	Start_Jog v= x	Starts the "Jog Mode" with a defined speed. "x" is the speed saved in the servo amplifier for the function "Jog Mode". A rising edge starts the motion, a falling edge cancels the motion.

Connector X11B			
1	In	MT Restart	Continues the motion task that was previously interrupted.
2	In	Start_MT I/O	Starts the motion task that is addressed by A0-A7 (connector X11A/1...8).
3	Out	InPos	When the target position for a motion task has been reached (the InPosition window), this is signaled by the output of a HIGH signal. <b>A cable break will not be detected.</b>
4	Out	Next-InPos	The start of each motion task in an automatically executed sequence of motion tasks is signaled by an inversion of the output signal. The output produces a LOW signal at the start of the first motion task of the sequence. The form of the message can be varied by using ASCII commands.
		PosReg 0	Can only be adjusted by ASCII commands/setup software.
5	Out	F_error	A LOW signal indicates that the position has gone outside the acceptable following error window.
6	Out	PosReg1	default: SW limit 1, indicated by a HIGH signal
7	Out	PosReg2	default: SW limit 2, indicated by a HIGH signal
8	Out	PosReg3	Can only be adjusted by ASCII commands/setup software.
9	Out	PosReg4	Can only be adjusted by ASCII commands/setup software.
10	Out	PosReg5	Can only be adjusted by ASCII commands/setup software.
11	-	24V DC	Supply voltage for output signals.
12	-	I/O-GND	Digital GND for the control system.

10.2.6

Connection diagram (default)

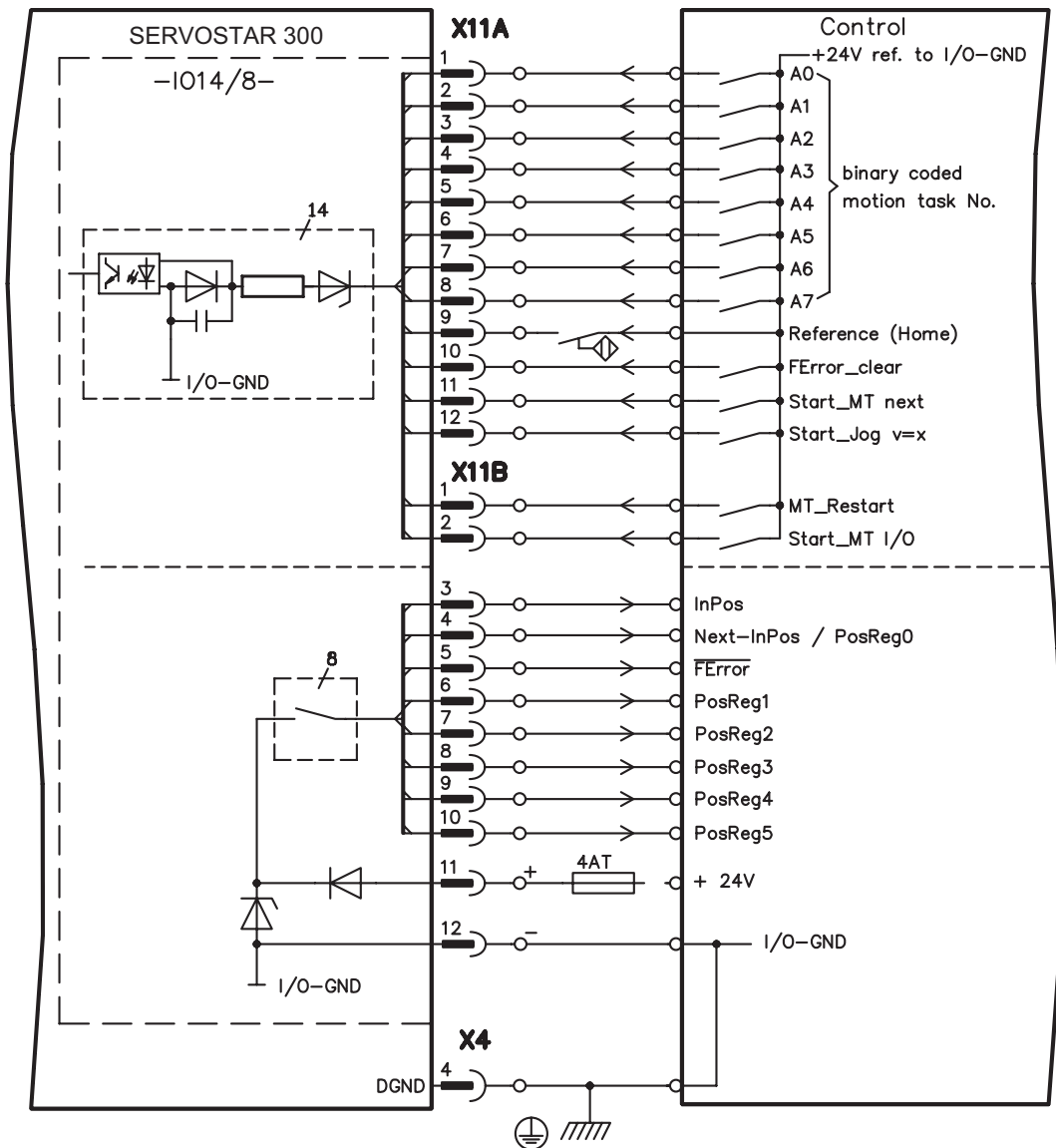

**10.3 Expansion card -PROFIBUS-**

This section describes the PROFIBUS expansion card for the SERVOSTAR 300. Information on the range of functions and the software protocol can be found in our manual "Communication Profile PROFIBUS DP".. The PROFIBUS expansion card has two 9-pin SubD sockets wired in parallel. The supply voltage for the expansion card is provided by the servo amplifier.

**10.3.1 Front view**

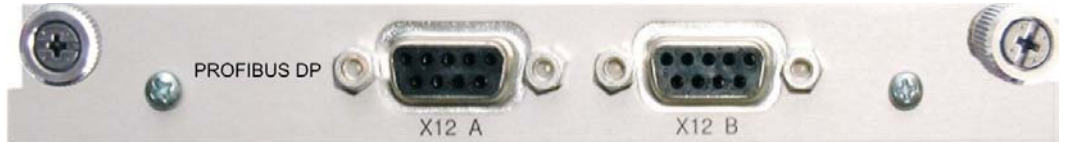

**10.3.2 Connection technology**

Cable selection, cable routing, shielding, bus connector, bus termination and transmission times are all described in the "Installation Guidelines for PROFIBUS-DP/FMS" from PNO, the PROFIBUS User Organization.

**10.3.3 Connection diagram**

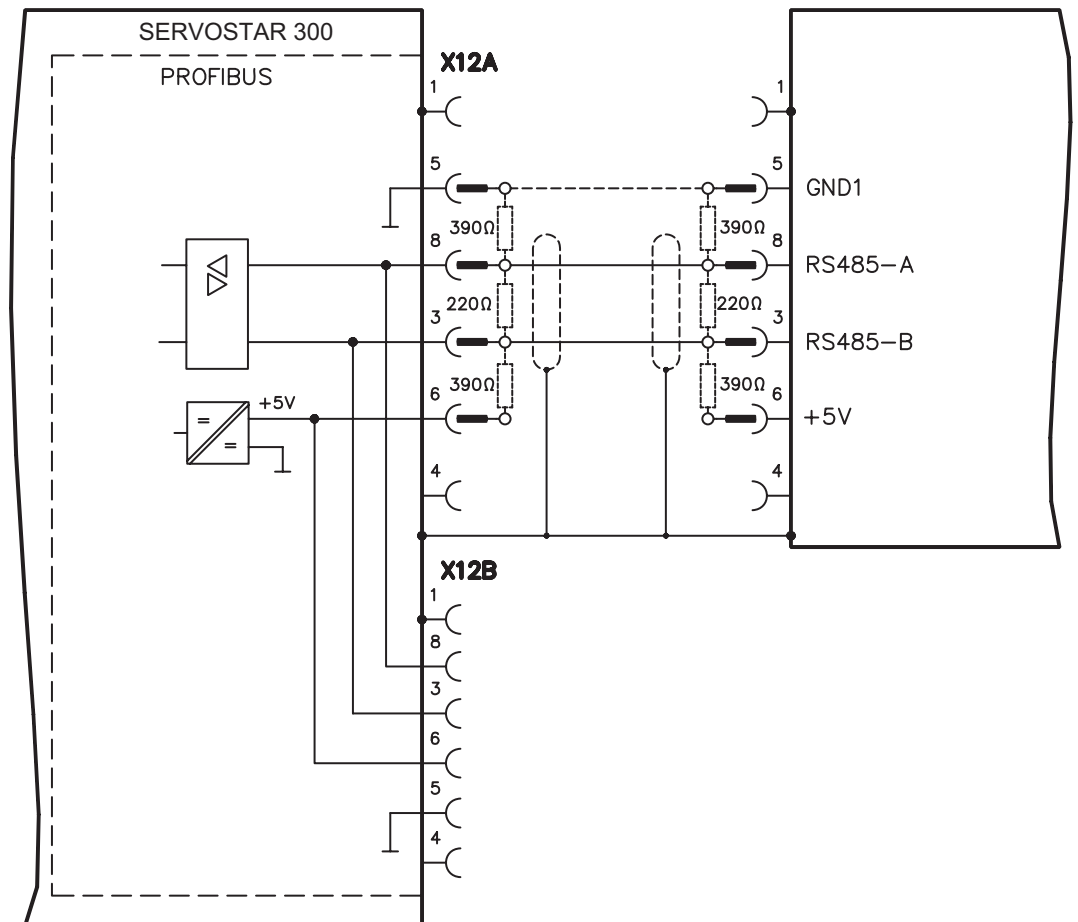



## 10.4 Expansion card -SERCOS-

This section describes the SERCOS expansion card for SERVOSTAR 300. Information on the range of functions and the software protocol can be found in our manual "IDN Reference Guide SERCOS".

### 10.4.1 Front view



### 10.4.2 LEDs

<b>RT</b>	Indicates whether SERCOS telegrams are being correctly received. In the final Communication Phase 4 this LED should flicker, since cyclical telegrams are being received.
<b>TT</b>	Indicates that SERCOS telegrams are being transmitted. In the final Communication Phase 4 this LED should flicker, since cyclical telegrams are being transmitted. Check the station addresses for the controls and the servo amplifier if: - the LED never lights up in SERCOS Phase 1 or - the axis cannot be operated, although the RT LED is lighting up cyclically.
<b>ERR</b>	Indicates that SERCOS communication is faulty or suffering from interference.  If this LED is very bright, then communication is suffering strong interference, or is non-existent. Check the SERCOS transmission speed for the controls and the servo amplifier (BAUD RATE) and the fiber-optic connection.  If this LED fades or flickers, this indicates a low level of interference for SERCOS communication, or the optical transmitting power is not correctly matched to the length of cable. Check the transmitting power of the (physically) previous SERCOS station. The transmitting power of the servo amplifier can be adjusted in the setup software DRIVEGUI.EXE on the SERCOS screen page, by altering the length parameter for the cable length.

### 10.4.3 Connection technology

For the fiber optic cable connection, only use SERCOS components to the SERCOS Standard IEC 61491.

#### Receive data

The fiber optic cable carrying receive data for the drive in the ring structure is connected to X13 with an F-SMA connector.

#### Transmit data

Connect the fiber optic cable for the data output to X14 by F-SMA connector.



### 10.4.4 Connection diagram

Layout of the SERCOS bus system in ring topology, with optical fiber cables (schematic).

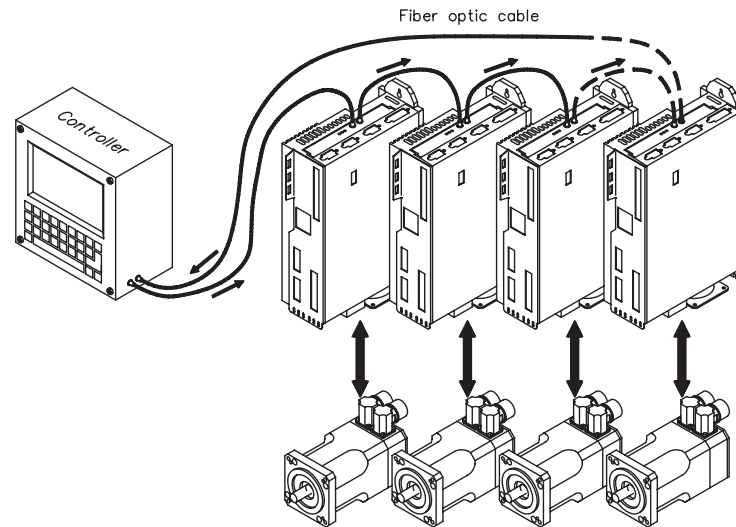

### 10.4.5 Modifying the station address

The drive address can be set to a value between 0 and 63. With address 0, the drive is assigned as an amplifier in the SERCOS ring. Set the station address with the:

#### **Keys on the front of the servo amplifier**

The SERCOS address can be modified using the keys on the front of the amplifier (p. 102).

#### **Setup software**

The address can also be modified in the setup software, "CAN/Fieldbus" screen (please refer to the setup software online help). Alternatively, enter the command **ADDR #** in the "Terminal" screen, where # is the new address of the drive.

### 10.4.6 Modifying the baud rate and optical power

If the baud rate is not set correctly, communication is not possible.

The **SBAUD #** parameter can be used to set the baud rate, where # is the baud rate. If the optical power is not set correctly, errors occur in telegram transmission and the red LED on the drive lights up. During normal communication, the green send and receive LEDs flash, giving the impression that the relevant LED is on.

The **SLEN #** parameter can be used to specify the optical range for a standard 1 mm<sup>2</sup> glass fibre cable, where # is the length of the cable in metres.

<b>SBAUD</b>		<b>SLEN</b>	
2	2 Mbaud	0	Very short connection
4	4 Mbaud	1...< 15	Length of the connection with a 1 mm <sup>2</sup> plastic cable
8	8 Mbaud	15...< 30	Length of the connection with a 1 mm <sup>2</sup> plastic cable
16	16 Mbaud	≥ 30	Length of the connection with a 1 mm <sup>2</sup> plastic cable

#### **Setup software**

The parameters can be modified in the setup software, "SERCOS" screen (please refer to the setup software the online help). Alternatively, the commands **SBAUD #** and **SLEN #** can be entered in the "Terminal" screen.

## 10.5 Expansion card -DEVICENET-

This section describes the DeviceNet expansion card for SERVOSTAR 300. Information on the range of functions and the software protocol can be found in our manual "DeviceNet Communication Profile".

### 10.5.1 Front view



### 10.5.2 Connection technology

Cable selection, cable routing, shielding, bus connector, bus termination and transmission times are all described in the "DeviceNet Specification, Volume I, II", published by ODVA.

### 10.5.3 Connection diagram

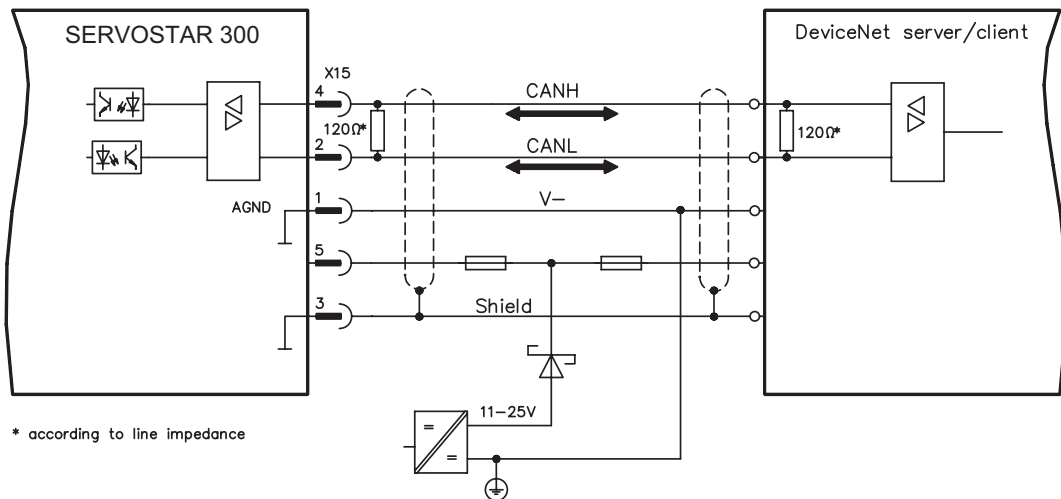

### 10.5.4 Combined module/network status-LED

LED	Meaning
<b>off</b>	The device is not online. <ul style="list-style-type: none"> <li>- The device has not yet finished the Dup_MAC_ID test.</li> <li>- The device is possibly not yet switched on.</li> </ul>
<b>green</b>	The device is operating as normal, is online, and the connections have been established. The device has been assigned to a master.
<b>blinking green</b>	The device is operating as normal, is online, but the connections have not been established. <ul style="list-style-type: none"> <li>- The device has passed the Dup_MAC_ID test and is online, but the connection to other nodes have not been established.</li> <li>- This device has not been assigned to a master.</li> <li>- Missing, incomplete or wrong configuration.</li> </ul>
<b>blinking red</b>	An error that can be cleared and/or at least one I/O connection are in a waiting state.
<b>red</b>	<ul style="list-style-type: none"> <li>- An error has occurred that cannot be cleared; it may be necessary to replace the device.</li> <li>- Communication device failure. The device has detected a fault that prevents communication with the network (for instance, a MAC ID appears twice or BUSOFF).</li> </ul>

### 10.5.5 Setting the station address (device address)

The station address for the servo amplifier can be set in three different ways:

- Set the rotary switches at the front of the expansion card to a value between 0 and 63. Each switch represents a decimal figure. For example, to set the address for the drive to 10, set MSD to 1 and LSD to 0.
- Set the rotary switches at the front of the expansion card to a value higher than 63. Now you can set up the station address by using the ASCII commands DNMACID x, SAVE, COLDSTART, whereby "x" stands for the station address.
- Set the rotary switches at the front of the expansion card to a value higher than 63. Now you can set up the station address by using the DeviceNet Object (Class 0x03, Attribute 1). This is normally carried out with the help of a DeviceNet software setup tool. You must save the parameters in non-volatile memory (Class 0x25, Attribute 0x65) and then restart the drive after setting/altering the address.

### 10.5.6 Setting the transmission speed

The DeviceNet transmission speed can be set in three different ways:

- Set the rotary switch for Baud rate (at the front of the option card) to a value between 0 and 2. 0 = 125 kbit/s, 1 = 250 kbit/s, 2 = 500 kbit/s.
- Set the rotary switch for Baud rate (at the front of the option card) to a value higher than 2. Now you can set the Baud rate by using the terminal commands DNBAUD x, SAVE, COLDSTART, whereby "x" stands for 125, 250 or 500 .
- Set the rotary switch for Baud rate (at the front of the option card) to a value higher than 2. Now you can set the Baud rate by using the DeviceNet Object (Class 0x03, Attribute 2) to a value between 0 and 2. This is normally carried out with the help of a DeviceNet software setup tool. You must save the parameters in non-volatile memory (Class 0x25, Attribute 0x65) and then restart the drive after altering the baud rate.

## 10.5.7

**Bus cable**

To meet ISO 898, a bus cable with a characteristic impedance of  $120\ \Omega$  should be used. The maximum usable cable length for reliable communication decreases with increasing transmission speed. As a guide, you can use the following values which we have measured, but they are not to be taken as assured limits.

General characteristic	Specification
Bit rates	125 kbit, 250 kbit, 500 kbit
Distance with larger bus connections	500 meters at 125 kBaud 250 meters at 250 kBaud 100 meters at 500 kBaud
Number of nodes	64
Signal environment	CAN
Modulation	Basic bandwidth
Coupling medium	DC-coupled differential transmit/receive operation
Isolation	500 V (option: optocoupler on the transceiver's node side)
Typical differential input impedance (recessive state)	Shunt C = 5pF Shunt R = $25\text{K}\Omega$ (power on)
Min. differential input impedance (recessive state)	Shunt C = $24\text{pF} + 36\ \text{pF/m}$ of the permanently attached stub cable Shunt R = $20\text{K}\Omega$
Absolute max. voltage range	-25 V to +18 V (CAN_H, CAN_L) The voltages for CAN_H and CAN_L refer to the ground pin of the transceiver. The voltage is higher than that on the V-terminal by the amount of the forward voltage drop of the Schottky diode. This voltage drop must be $< 0.6\text{V}$ .

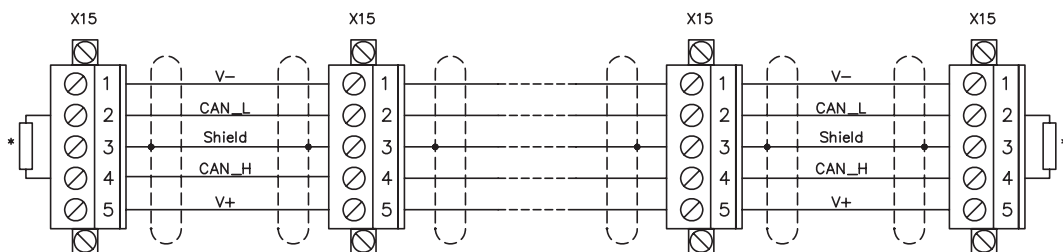

\* according to line impedance about  $120\ \Omega$

**Grounding:**

The DeviceNet network must only be grounded at one point, to avoid ground loops. The circuitry for the physical layer in all devices are referenced to the V-bus signal. The ground connection is made via the power supply for the bus system. The current flowing between V- and ground must not flow through any device other than the power supply.

**Bus topology:**

The DeviceNet medium utilizes a linear bus topology. Termination resistors are required at each end of the connecting cable. Stub cables are permitted up to a length of 6 meters, so that at least one node can be connected.

**Termination resistors:**

DeviceNet requires a termination **at each end** of the connecting cable.

These resistors must meet the following requirements:  $120\ \Omega$ , 1% metal-film,  $1/4\ \text{W}$

**10.6 Expansion card -ETHERCAT-**

This section describes the EtherCAT expansion card for SERVOSTAR 300. Information on the range of functions and the software protocol can be found in the EtherCAT documentation. This expansion cards enables the servo amplifier to be connected to the EtherCAT network via RJ-45 connectors (IN and OUT ports).

**10.6.1 Front view**



**10.6.2 LEDs**

LED	Function
<b>ERROR</b>	flickering = Booting Error blinking = Invalid Configuration single flash = Unsolicited State Change double flash = Watchdog Timeout off = No Error
<b>RUN</b>	on = Device is in state OPERATIONAL blinking = Device is in state PRE-OPERATIONAL single flash = Device is in state SAFE-OPERATIONAL off = Device is in state INIT
<b>ACT IN</b>	on = linked, but not active at X20A (in) flickering = linked and active at X20A (in) off = not linked at X20A (in)
<b>ACT OUT</b>	on = linked, but not active at X20B (out) flickering = linked and active at X20B (out) off = not linked at X20B (out)

**10.6.3 Connection diagram**

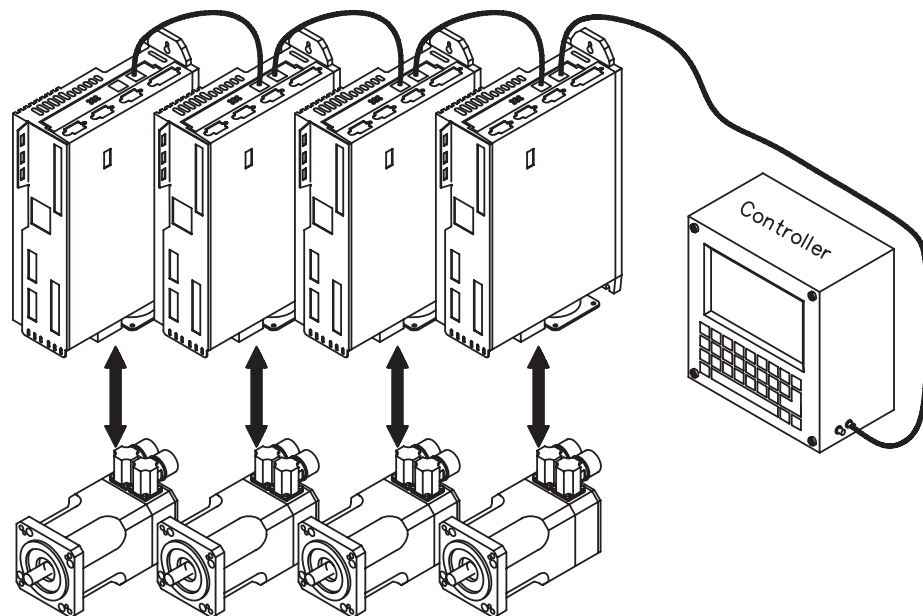

## 10.7 Expansion card -SYNQNET-

This section describes the SynqNet expansion card for SERVOSTAR 300. Information on the range of functions and the software protocol can be found in the SynqNet documentation.

### 10.7.1 Front view

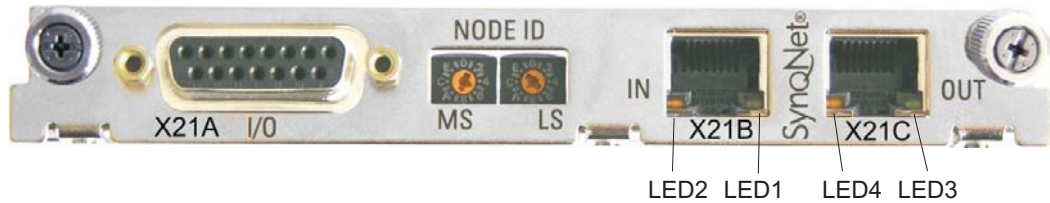

### 10.7.2 NODE ID Switch

With these hexadecimal switches you can set the main and low significant bytes of the Node ID separately. SynqNet does not require an address for correct operation in the network, however in some machines this can be a convenient way of identifying build options to the application program.

### 10.7.3 Node LED table

LED#	Name	Function
LED1, green	LINK_IN	ON = receive valid (IN port) OFF = not valid, power off, or reset.
LED2, yellow	CYCLIC	ON = network cyclic BLINK = network not cyclic OFF = power off, or reset
LED3, green	LINK_OUT	ON = receive valid (OUT port) OFF = not valid, power off, or reset
LED4, yellow	REPEATER	ON = repeater on, network cyclic BLINK = repeater on, network not cyclic OFF = repeater off, power off, or reset

### 10.7.4 SynqNet Connection, Connector X21B/C (RJ-45)

Connection to the SynqNet network via RJ-45 connectors (IN and OUT ports) with integrated LEDs.

10.7.5 Digital inputs/outputs, connector X21A (SubD 15-pin, socket)

Inputs (In): 24V (20...28V), opto-isolated, one high-speed input (Pin 4)  
 Outputs (Out): 24V, opto-isolated, Darlington driver

Pinout connector X21A (SubD 15 pin)							
Pin	Type	Description		Pin	Type	Description	
1	In	+24V	power supply	9	In	GND	power supply
2	Out	NODE-ALARM	indicates a problem with the node	10	Out	OUT_00	digital output
3	Out	OUT_01	digital output	11	Out	OUT_02	digital output
4	In	IN_00	capture input (fast)	12	In	IN_02	digital input
5	In	IN_04	digital input	13	In	IN_03	digital input
6	In	IN_01	digital input	14	In	NEGLIM	limit switch, negative direction
7	In	HOME	reference switch	15	In	NODE-DISABLE	disables Node
8	In	POSLIM	limit switch, positive direction				

10.7.6 Connection diagram digital inputs/outputs, connector X21A

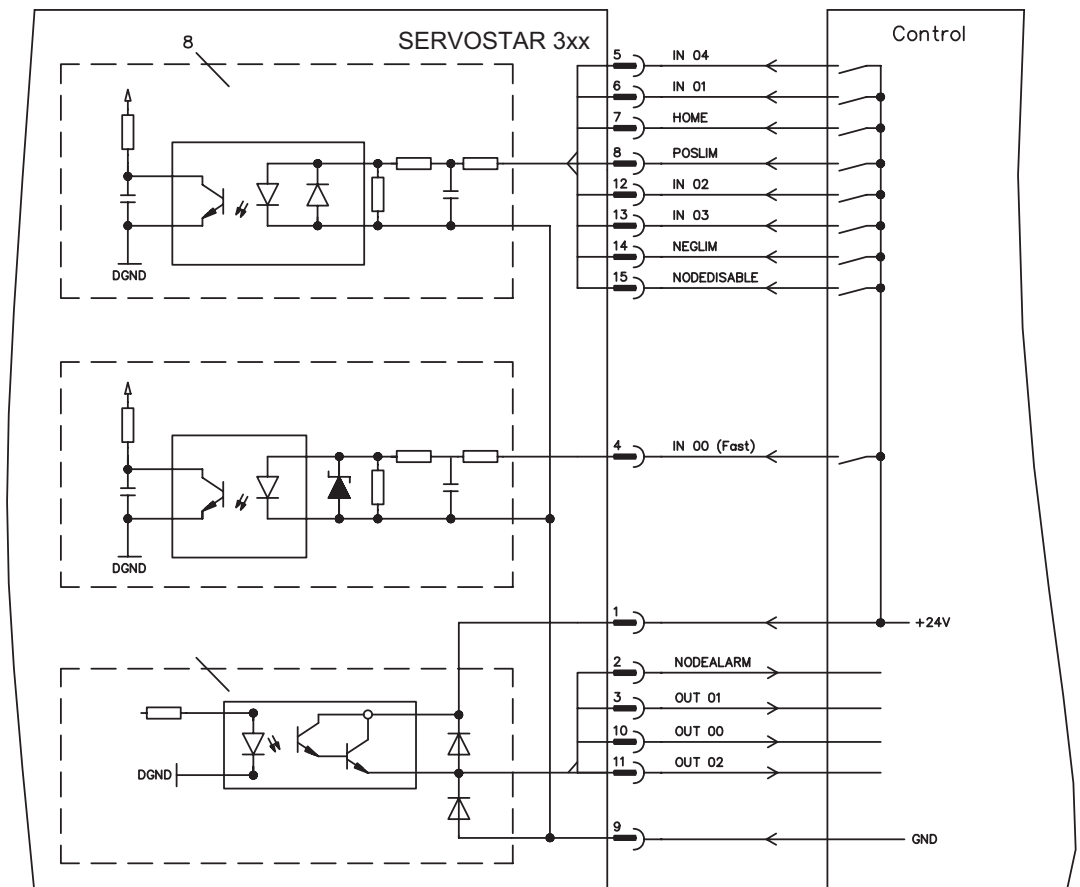



## 10.8 Expansion module -2CAN-

Connector X6 of the SERVOSTAR is assigned to the signals for the RS232 interface and the CAN interface. It is therefore not the standard pin assignment for these interfaces, and a special cable is required to be able to use both interfaces simultaneously.

The -2CAN- expansion module provides the interfaces on separate Sub-D connectors.

The two CAN connectors are wired in parallel. A termination resistor (120  $\Omega$ ) for the CAN bus can be switched into circuit if the SERVOSTAR is at the end of the bus.

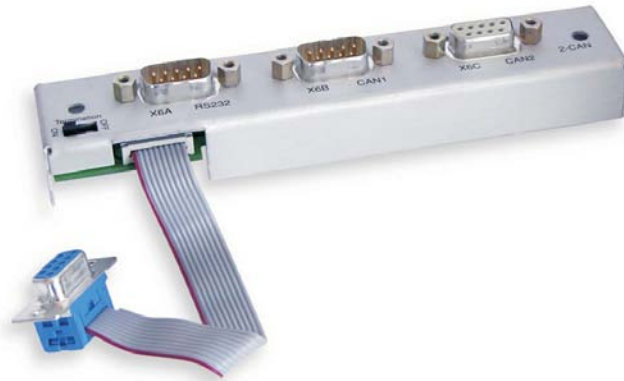

### 10.8.1 Installation

The modul must be placed onto the option slot after levering off the cover of the option slot and replacing the small cover (see p. 107):



- **Screw the distance pieces into the fixing lugs of the option slot.**
- **Place the expansion module onto the option slot.**
- **Screw the screws into the threads of the distance pieces.**
- **Plug the Sub-D9 socket into connector X6 on the SERVOSTAR**

### 10.8.2 Front view



### 10.8.3 Connection technology

Standard shielded cables can be used for the RS232 and CAN interfaces.



**If the servo amplifier is the last device on the CAN bus, then the switch for the bus termination must be set to ON.**

**Otherwise, the switch must be set to OFF (condition as delivered).**



10.8.4 Connector assignments

RS232		CAN1=CAN2	
X6A Pin	Signal	X6B=X6C Pin	Signal
1	Vcc	1	
2	RxD	2	CAN-Low
3	TxD	3	CAN-GND
4		4	
5	GND	5	
6		6	
7		7	CAN-High
8		8	
9		9	

10.8.5 Connection diagram

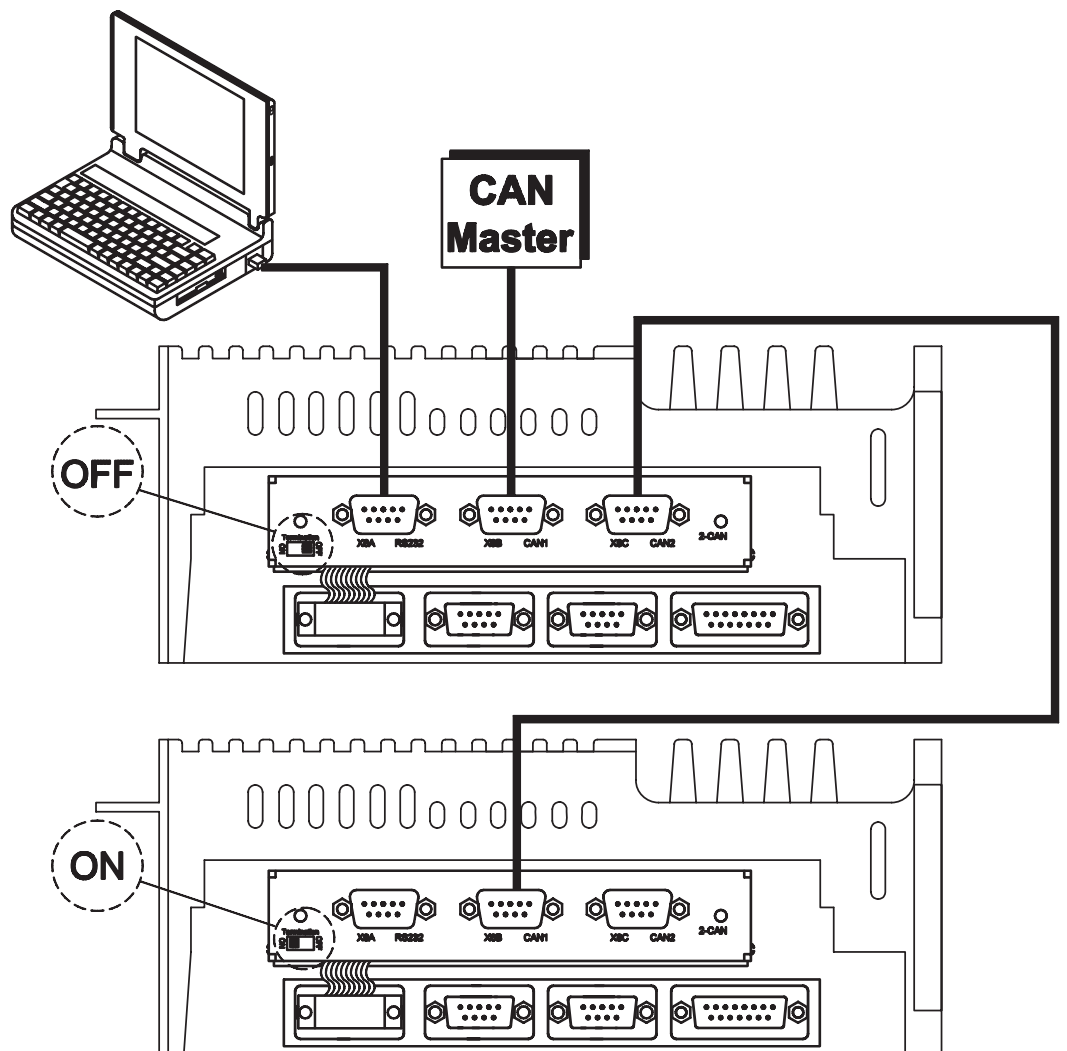

## 10.9

**Option "FAN", ventilator control**

To reduce the average noise emission of servo amplifiers with fan, these amplifiers can be ordered with built-in fan option card (ventilator control). This option uses (invisible from the outside) the extension slot.



**The option FAN cannot be inserted later. Order the amplifier with built-in FAN option.**

**Function**

The fan is switched on and off depending on the inner temperature of the servo amplifier. That reduces the average noise emission.

**Switching temperature**

<b>Monitoring</b>	<b>FAN off</b>	<b>FAN on</b>
Internal temperature	55°C	58°C
Heat sink temperature	60°C	65°C

## 11 Appendix

### 11.1 Glossary

<b>B</b>	Brake circuit	Converts superfluous energy fed back by the motor during braking (regenerated energy) into heat.
<b>C</b>	Clock	Clock signal
	Common-mode voltage	The maximum amplitude of a disturbance (on both inputs) which a differential input can eliminate
	CONNECT modules	Modules built into the servo amplifier, with integrated position control, that provide special versions of the interface for the connection to the higher-level control.
	Counts	Internal count pulses, 1 pulse = $1/2^{20}$ turn <sup>-1</sup>
	Continuous power of brake circuit	Mean power that can be dissipated in the brake circuit
	Current controller	Regulates the difference between the current setpoint and the actual value to 0 Output : power output voltage
<b>D</b>	DC bus link	Rectified and smoothed power voltage
	Disable	Removal of the ENABLE signal
<b>E</b>	Earth short	electrical connection between a phase and the protective earth (PE)
	Enable	Enable signal for the servo amplifier, Hardware-Enable with 24V signal to X3, Software-Enable command by setup Software, fieldbus or permanently set. Both are required for enabling the amplifier.
	ENABLE	Enable signal for the servo amplifier (+24 V)
<b>F</b>	Fieldbus interface	CANopen, PROFIBUS, SERCOS etc.
	Final speed (limit speed)	Maximum value for the speed normalization at $\pm 10$ V
<b>G</b>	GRAY-code	Special format for representing binary numbers
<b>H</b>	Holding brake	Brake in the motor, that can only be used when the motor is at standstill
<b>I</b>	I <sup>2</sup> t threshold	Monitoring of the r.m.s. current that is actually required
	Input drift	Temperature and age-dependent alteration of an analog input
	Incremental encoder interface	Position signaling by 2 signals with 90° phase difference (i.e. in quadrature), is not an absolute position output
	I <sub>peak</sub> , peak current	The effective value of the peak current
	I <sub>rms</sub> , effective current	The r.m.s. value of the continuous current
<b>K</b>	K <sub>p</sub> , P-gain	Proportional gain of a control loop
<b>L</b>	Limit speed (final speed)	Maximum value for speed normalization at $\pm 10$ V
	Limit switch	Switch limiting the traverse path of the machine; implemented as n.c. (break) contact

<b>M</b>	Machine	The complete assembly of all connected parts or devices, of which at least one is movable
	Motion block	Data packet with all the position control parameters which are required for a motion task
	Multi-axis system	Machine with several independently driven axes
<b>N</b>	Natural convection	Free movement of air for cooling
<b>O</b>	Optocoupler	Optical connection between two electrically independent systems
<b>P</b>	P-controller	Control loop with purely proportional behavior
	Phase shift	Compensation for the lag between the electro-magnetic and magnetic fields in the motor
	PI-controller	Control loop with proportional and differential behavior
	Position controller	Regulates the difference between the position setpoint and the actual position to 0 Output: speed setpoint
	Potential isolation	electrically decoupled, electrical isolation
	Power contactor	System protection device with phase monitoring
	Pulse power of the brake circuit	Maximum power which can be dissipated in the brake circuit
<b>R</b>	Reset	New start of the microprocessor
	Resolver/digital converter	Conversion of the analog resolver signals into digital information
	Reversing mode	Operation with a periodic change of direction
	Ring core	Ferrite rings for interference suppression
	ROD-interface	Incremental position output
<b>S</b>	Servo amplifier	Control device for regulating the speed, torque and position of a servomotor
	Setpoint ramps	Limits for the rate of change of the speed setpoint
	Short-circuit	here: electrically conductive connection between two phases
	Speed controller	Regulates the difference between the speed setpoint and the actual value to 0 Output : current setpoint
	SSI-interface	Cyclically absolute, serial position output
	Supply filter	Device to divert interference on the power supply cables to PET
	Tachometer voltage	Voltage proportional to the actual speed
	Thermal control	Temperature-sensitive device built into the motor winding (usually a PTC)
	Tn, I-integration time	Integral component of a control loop
<b>Z</b>	Zero pulse	Output once per turn from incremental encoders, used to zero the machine

## 11.2 Order codes

The order numbers of accessories such as cables, brake resistors, mains supplies, etc., can be found in the accessories manual.

### 11.2.1 Servo amplifiers

Article	Rated voltage	Order code
<b>SERVOSTAR 303</b>	110-230 V AC	S30361-NA*
<b>SERVOSTAR 306</b>	110-230 V AC	S30661-NA*
<b>SERVOSTAR 306-FAN</b>	110-230 V AC	S30661-FN
<b>SERVOSTAR 310</b>	110-230 V AC	S31061-NA*
<b>SERVOSTAR 310-FAN</b>	110-230 V AC	S31061-FN
<b>SERVOSTAR 341</b>	208-480 V AC	S30101-NA*
<b>SERVOSTAR 343</b>	208-480 V AC	S30301-NA*
<b>SERVOSTAR 343-FAN</b>	208-480 V AC	S30301-FN
<b>SERVOSTAR 346</b>	208-480 V AC	S30601-NA*
<b>SERVOSTAR 346-FAN</b>	208-480 V AC	S30601-FN

\* NA means without built-in expansion card

### 11.2.2 Expansion cards

Article	EU order code	US order code
<b>Expansion card DeviceNet</b>	DE-103571	OPT-DN
<b>Expansion card PROFIBUS DP</b>	DE-106712	OPT-PB3
<b>Expansion card SERCOS</b>	DE-90879	OPT-SE
<b>Expansion card I/O-14/08</b>	DE-90057	OPT-EI
<b>Expansion card EtherCat</b>	DE-108350	OPT-EC
<b>Expansion card SynqNet</b>	DE-200073	OPT-SN
<b>Expansion module 2CAN</b>	DE-101174	not available

### 11.2.3 Mating connectors

Article	EU order code	US order code
<b>Mating connector X3</b>	DE-107554	CON-S3X3
<b>Mating connector X4</b>	DE-107555	CON-S3X4
<b>Mating connector X0 (110...230V)</b>	DE-105856	CON-S3X0L
<b>Mating connector X8 (110...230V)</b>	DE-107556	CON-S3X8L
<b>Mating connector X9 (110...230V)</b>	DE-107631	CON-S3X9L
<b>Mating connector X0 (208...480V)</b>	DE-107557	CON-S3X0H
<b>Mating connector X8 (208...480V)</b>	DE-107558	CON-S3X8H
<b>Mating connector X9 (208...480V)</b>	DE-107467	CON-S3X9H

### 11.3 Repair-/Disposal request Telefax form

To

Danaher Motion GmbH  
 Wacholderstr. 40-42  
 40489 Düsseldorf  
 Deutschland

Fax: +49 (0) 203 9979 444

Please advise dispatch information for (please select)

- Repair**
- Disposal**

of these products:

Product	Serial number	Reason ("fault", "return" or similar)

to this address:

<b>Company</b>	
<b>Street</b>	
<b>Zip / Town</b>	
<b>Country</b>	
<b>Specialist Name</b>	
<b>Telephone</b>	
<b>Telefax</b>	
<b>E-Mail</b>	

\_\_\_\_\_  
 City, Date

\_\_\_\_\_  
 Signature

## 11.4 Index

<b>I</b>	24V aux. supply, interface . . . . .	59	<b>H</b>	Hardware requirements . . . . .	91
<b>A</b>	Abbreviations . . . . .	8		Hiperface encoder interface. . . . .	67
	Ambient temperature . . . . .	24		Humidity	
	AS ENABLE . . . . .	84		in operation . . . . .	24
	Assembly . . . . .	46		Storage . . . . .	15
<b>B</b>	Baud rate . . . . .	101	<b>I</b>	Inputs	
	BISS encoder interface . . . . .	65		Analog . . . . .	83
	Block diagram (overview) . . . . .	55		Digital . . . . .	84
	Brake circuit . . . . .	26		Installation	
	Brake resistor			Electrical . . . . .	49
	Interface, ext. . . . .	61		Expansion cards . . . . .	107
	Technical data . . . . .	26		Mechanical. . . . .	45
	Brake, see also motor-holding brake . . . . .	25		Software . . . . .	91
	BTB/RTO . . . . .	85	<b>K</b>	Keypad operation . . . . .	101
<b>C</b>	CAN-bus cable . . . . .	87	<b>L</b>	Leakage current. . . . .	42
	CANopen interface . . . . .	87		LED display . . . . .	101
	CE conformance . . . . .	12	<b>M</b>	Maintenance . . . . .	15
	ComCoder. . . . .	71		Master-slave . . . . .	78
	Conductor cross-sections . . . . .	24		Motor interface . . . . .	62
	Connection diagram. . . . .	57		Mounting position . . . . .	24
	Connection technology . . . . .	52	<b>N</b>	Nameplate. . . . .	17
	Connector assignments. . . . .	56		Noise emission . . . . .	24
	Connectors . . . . .	23	<b>O</b>	Operating systems . . . . .	91
<b>D</b>	DC bus link, interface . . . . .	61		Optical power, SERCOS. . . . .	113
	Disassembling. . . . .	16		Option FAN . . . . .	122
	Disposal . . . . .	16		Order codes . . . . .	125
<b>E</b>	Electronic Gearing . . . . .	78		Outputs	
	ENABLE. . . . .	84		BTB/RTO . . . . .	85
	Enclosure protection . . . . .	24		DIGI-OUT 1/2 . . . . .	85
	Encoder emulation . . . . .	81	<b>P</b>	Package supplied . . . . .	17
	EnDat encoder interface . . . . .	66		Packaging . . . . .	15
	Error messages . . . . .	104		Part number scheme . . . . .	18
	Expansion card			PC cable . . . . .	86
	-2CAN-. . . . .	120		PC connection. . . . .	86
	-DeviceNet-. . . . .	114		Pollution level . . . . .	24
	-EtherCat-. . . . .	117	<b>Q</b>	Quickstart . . . . .	92
	Guide to installation . . . . .	107	<b>R</b>	RCD . . . . .	42
	-I/O-14/08-. . . . .	108		Re-forming . . . . .	89
	-PROFIBUS-. . . . .	111		Repair . . . . .	16
	-SERCOS-. . . . .	112		Reparaturanfrage . . . . .	126
	-SynqNet-. . . . .	118		Resolver, interface . . . . .	64
	External fusing . . . . .	23		Restart lock -AS-. . . . .	36
<b>F</b>	Feedback . . . . .	63		ROD, interface . . . . .	81
<b>G</b>	Glossary . . . . .	123		RS232/PC, interface . . . . .	86
	Ground symbol . . . . .	51			
	Grounding				
	Connection diagram . . . . .	57			
	Installation . . . . .	50			

<b>S</b>	Safety instructions. . . . .	10
	Setup . . . . .	89
	Shielding	
	Connection diagram,. . . . .	57
	Installation . . . . .	50
	Shock-hazard protection . . . . .	42
	Site . . . . .	45
	Site altitude . . . . .	24
	SSI, interface . . . . .	82
	Stacking height . . . . .	15
	Standards. . . . .	9
	Station address, CAN-bus. . . . .	101
	Storage . . . . .	15
	Supply connection, interface . . . . .	59
	Supply networks. . . . .	58
	Supply voltage . . . . .	24
	Switch-on/switch-off behavior. . . . .	28
	Symbols. . . . .	9
	System components, overview . . . . .	54
<b>T</b>	Target group . . . . .	7
	Technical data. . . . .	21
	Tightening torques, connectors . . . . .	23
	Transport . . . . .	15
<b>U</b>	Use as directed	
	Restart lock AS . . . . .	37
	Servo amplifiers . . . . .	11
	Setup software. . . . .	90
<b>V</b>	Ventilation	
	Installation . . . . .	45
	Technical data . . . . .	24
	Vibrations . . . . .	24
<b>W</b>	Warning messages . . . . .	105
	Wiring . . . . .	50



This page has been deliberately left blank.

## **Sales and Service**

We are committed to quality customer service. In order to serve in the most effective way, please contact your local sales representative for assistance.

If you are unaware of your local sales representative, please contact us.

### **Europe**

#### **Danaher Motion Customer Support Europe**

Internet [www.DanaherMotion.com](http://www.DanaherMotion.com)

E-Mail [support\\_dus.germany@danahermotion.com](mailto:support_dus.germany@danahermotion.com)

Tel.: +49(0)203 - 99 79 - 0

Fax: +49(0)203 - 99 79 - 216

### **North America**

#### **Danaher Motion Customer Support North America**

Internet [www.DanaherMotion.com](http://www.DanaherMotion.com)

E-Mail [DMAC@danahermotion.com](mailto:DMAC@danahermotion.com)

Phone: +1 - 540 - 633 - 3400

Fax: +1 - 540 - 639 - 4162

**KOLLMORGEN**

---